

SILICONA | EPDM | SBR | NBR | TPE | CEDULARES | CR | FKM | FFKM

Perfiles | Juntas | Materias Primas | Pavimentos

Piezas al corte | Troqueladas | Moldeadas

ECATEC

ELABORADORA DE CAUCHOS TÉCNICOS



CATÁLOGO

CATÁLOGO GENERAL
2025

ECATEC.ES

Perfilamos tus ideas

ECATEC

ELABORADORA DE CAUCHOS TÉCNICOS

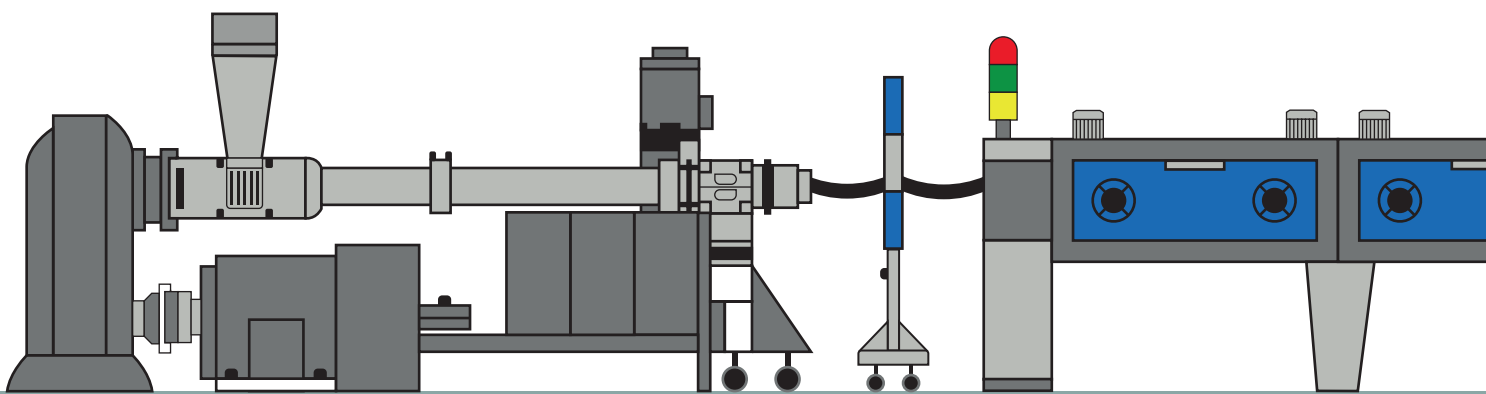

○ MATERIALES	6	Ⓐ PERFILES PARA CONTAINER BASURA	22
≡ JUNTAS DE EVACUACIÓN DE GASES Y HUMOS	10	⚡ PERFILES DE COEXTRUSIÓN	23
~ JUNTAS PARA TUBERÍAS	12	⓪ DEFENSAS FORMA D	24
≡ JUNTAS DE VENTILACIÓN DE GASES Y HUMOS	12	Ⓜ PERFILES FORMA e	25
⤴ JUNTAS DE ESTANQUEIDAD PARA BIDONES	13	└ PERFILES FORMA L O CANTONERA	26
⓪ JUNTAS HINCHABLES	15	⓪ PERFILES MEDIA CAÑA	28
└ JUNTAS DE ESTANQUEIDAD PARA VÁLVULAS DE COMPUERTAS	16	∞ PERFILES PARA PISTAS DE HIELO	34
Ⓒ PERFILES CON ARMA METÁLICA	17	⊥ PERFILES FORMA T	35
∫ PERFILES PARA ABRAZADERAS GÁSMICAS, METÁLICAS E ISOFÓNICAS	18	Ω PERFILES OMEGA	36
⤴ PERFILES PARA CABALLETE CRISTAL / JUNQUILLO	19	▲ PERFILES TRAPECIO ISÓSCELES Y ESCALENO	37
⤴ PERFILES PARA CIERRE DE PUERTAS Y VENTANAS	20	Ⓜ PERFILES FORMA U	39
└ PERFILES PARA CARROCERÍAS	21	⓪ PERFILES FORMA 9 O NOTA MUSICAL	53
		↪ PERFILES VARIOS	56

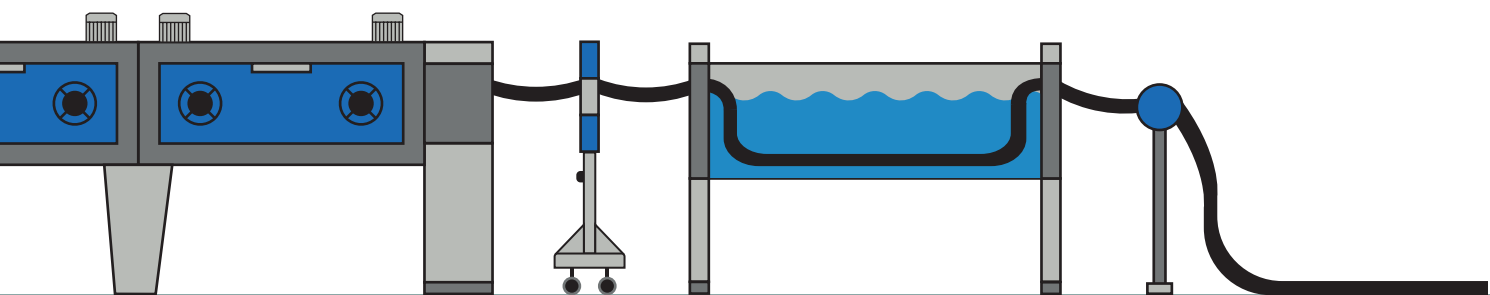

MATERIALES

Caucho etileno-propileno-dieno EPDM

Tipo de caucho sintético utilizado para una amplia gama de aplicaciones como automoción, construcción, juntas industriales, etc.

Las membranas de caucho EPDM tienen gran resistencia a cambios de temperatura bruscos, al envejecimiento, al ozono y a numerosos productos químicos corrosivos. Resistencia a muchos ácidos, álcalis, detergentes, cetonas, alcoholes y glicoles y elevadas propiedades mecánicas.

Así mismo se pueden conseguir formulaciones con elevados niveles de aislamiento eléctrico, ignifugabilidad de grado medio o que permiten el contacto con agua potable. El caucho EPDM estándar es negro de 65 Shore.

PROPIEDADES

Dureza (Shore A)	Trabajo (°C)	Tolerancias	Colores	Aplicaciones	Certificaciones
50 a 85	-45 a 120	ISO 3302-1996 (E) E AND L CLASS EXTRUSION ISO 3302-1996 (E) M-CLASS CLASS MOLDEO	Negro Blanco Gris	Automoción Construcción Sector eléctrico Juntas industriales Tuberías Suministros	

Caucho cedular SBR-NBR

El Caucho Cedular se produce de elastómeros de base de caucho natural y/o sintético con la adición de agentes esponjantes. El EPDM cedular debe esta esponjosidad a las cédulas de aire que se encapsularon en el momento de su fabricación, tiene buena resistencia a la compresión y a la deformación permanente.

Es hermético y estanco (cédula cerrada). Ámbitos de aplicación del caucho cedular: juntas de estanqueidad de aire, agua fría y caliente, polvo, aceites y grasas, ácidos y bases diluidas, rayos U.V, ozono. También se utiliza en aislamiento acústico y vibración.

El EPDM cedular estándar es en color negro con una densidad de 0,70 gr/cm³.

PROPIEDADES

Dureza (Shore A)	Trabajo (°C)	Tolerancias	Colores	Aplicaciones	Certificaciones
0.4 a 0.9	-30 a 100	ISO 3302-1996 (E) E AND L CLASS EXTRUSION ISO 3302-1996 (E) M-CLASS CLASS MOLDEO	Negro Beige	Se pueden utilizar prácticamente en todos los ámbitos de la industria, para sellar, retener, aislar y amortiguar.	

Caucho silicona VMQ-PVMQ

El caucho de silicona es un derivado de la roca de cuarzo combinado a altas temperaturas con carbono. Es considerado buen aislante eléctrico y en contacto con llamas arde con dificultad.

Presentan una excelente resistencia al aire caliente y una flexibilidad extrema a bajas temperaturas. Es extraordinaria su resistencia al ozono, intemperie, ambientes salinos y radiación ultravioleta.

Siliconas disponibles de producción: silicona estándar aislante (MVQ), silicona conductora, silicona para tratamiento corona, silicona para vapor, fluoro silicona (FVMQ), silicona para muy altas temperaturas (THT), silicona para muy bajas temperaturas (PMVQ), silicona platino. La silicona estándar es traslúcida de 65 Shore A

PROPIEDADES

Dureza (Shore A)	Trabajo (°C)	Tolerancias	Colores	Aplicaciones	Certificaciones
25 a 85	-70 a 220	ISO 3302-1996 (E) E AND L CLASS EXTRUSION ISO 3302-1996 (E) M-CLASS CLASS MOLDEO	Cualquier color, siguiendo la carta RAL o PANTONE	Generalmente son juntas de estanqueidad, para todo tipo de industrias, especialmente las de los fabricantes de maquinaria.	Farmacopea Europea 3ª edición USP XXV Clase VI Ausencia de transferencia de sabor, FDA (CFR21 sección 177.2600, etc.)

Caucho silicona cedula

La silicona cedula o también llamada silicona esponjosa debe esta característica a las cédulas de aire que se encapsularon en el momento de su fabricación, tiene buena resistencia a la compresión y a la deformación permanente. Proporciona una excelente adaptabilidad a superficies irregulares o que han sufrido algún desgaste y disminuye su conductividad térmica.

Este material es usado en juntas de estanqueidad, industria alimentaria, automoción, juntas de aislamiento, etc. No se aconseja el contacto con grasas y aceites. La silicona cedula estándar es en color blanco roto o negro con una densidad de 0,25 gr/cm³.

PROPIEDADES

Dureza (Shore A)	Trabajo (°C)	Tolerancias	Colores	Aplicaciones	Certificaciones
10 a 35	-50 a 200	ISO 3302-1996 (E) E AND L CLASS EXTRUSION ISO 3302-1996 (E) M-CLASS CLASS MOLDEO	Cualquier color, salvo traslúcido, siguiendo la carta RAL o PANTONE	Se pueden utilizar prácticamente en todos los ámbitos de la industria, para sellar, retener, aislar y amortiguar.	Farmacopea Europea 3ª edición USP XXV Clase VI Ausencia de transferencia de sabor, FDA (CFR21 sección 177.2600, etc.)

MATERIALES

Caucho estireno-butadieno Rubber SBR

Presenta moderada resistencia al desgarro, ozono y a la intemperie, por tener las cadenas moleculares insaturadas. El caucho SBR tiene buena resistencia química a productos químicos inorgánicos, pero no a los ácidos oxidantes, limitada a los ácidos minerales, no siendo adecuada para líquidos orgánicos en general.

Este material es idóneo para juntas de estanqueidad. El caucho SBR estándar es negro de 65 Shore A.

PROPIEDADES

Dureza (Shore A)	Trabajo (°C)	Tolerancias	Colores	Aplicaciones	Certificaciones
60 a 70	-50 a 90	ISO 3302-1996 (E) E AND L CLASS EXTRUSION ISO 3302-1996 (E) M-CLASS CLASS MOLDEO	Negro Blanco Gris Beige	Juntas	

Caucho nitrilo-butadieno Rubber NBR

Es un tipo de caucho sintético, su principal característica es la resistencia a los aceites, además tiene buenas propiedades mecánicas como tracción, compresión, flexión, e impermeabilización a los gases. Presenta una buena adhesividad al acero y presenta un moderado envejecimiento. No se recomienda para hidrocarburos, clorinados, acetonas y otros agentes oxidantes.

Su combinación con PVC mejora su pobre resistencia al ozono y a la intemperie y hace posible que pueda ser aplicado a exteriores. El caucho NBR estándar es negro de 70 Shore A. El caucho NBR estándar es negro de 70 Shore A.

PROPIEDADES

Dureza (Shore A)	Trabajo (°C)	Tolerancias	Colores	Aplicaciones	Certificaciones
60 a 80	-40 a 100	ISO 3302-1996 (E) E AND L CLASS EXTRUSION ISO 3302-1996 (E) M-CLASS CLASS MOLDEO	Negro	Automoción en tubos de conducción de gasolina, juntas y retenes y en general todo aquello que tiene permanente contacto con aceites.	

Termoplástico vulcanizado TPV

Los Termoplásticos vulcanizados dinámicamente (TPV) son un tipo especial de termoplásticos elastómeros (TPE) con los que se obtienen mejores propiedades debido al exclusivo sistema de mezclado que consigue vulcanizar dinámicamente una fase discreta de elastómero inmersa en una fase continua de termoplástico

TPV Elastoprene es un material completamente reciclable y reutilizable en el punto de transformación, siendo respetuoso con el medio ambiente y mejorando la rentabilidad de los procesos, lo que representa una ventaja añadida sobre las piezas y procesos de goma. TPV Elastoprene tiene buena resistencia al ozono, UV y al ataque de diversos productos químicos, mientras que presenta una temperatura de servicio de hasta 125°C

PROPIEDADES

Dureza (Shore A)	Trabajo (°C)	Tolerancias	Colores	Aplicaciones	Certificaciones
60 a 67	170 a 200	ISO 868 ISO 815	Negro	Perfiles de estanqueidad extruídos y co-extruídos. productos con acabados en flock, cintas adhesivas	

Termoplástico TPE

El TPE es un material de tipo caucho que se puede procesar con tecnologías termoplásticas como el moldeo por inyección, el moldeo 2K o la extrusión. Los elastómeros termoplásticos (TPE) son compuestos de materiales termoplásticos como PP, PBT o PA combinados con material de caucho suave y, a menudo, la incorporación de aditivos como aceites o cargas.

Son una clase de polímeros o mezcla física de polímeros (generalmente un plástico y un caucho) que dan lugar a materiales con características termoplásticas y elastoméricas, además son reciclables, puesto que, al igual que los termoplásticos en general, pueden ser reutilizados después de ser transformados. Tienen características elásticas típicas de los cauchos, pero estos no son reciclables por temperatura, debido a su carácter entrecruzado que le impide fundirse al calentarlo.

PROPIEDADES

Dureza (Shore A)	Trabajo (°C)	Tolerancias	Colores	Aplicaciones	Certificaciones
60 a 67	170 a 200	ISO 868 ISO 815	Negro	Perfiles de estanqueidad extruídos y co-extruídos. productos con acabados en flock, cintas adhesivas	

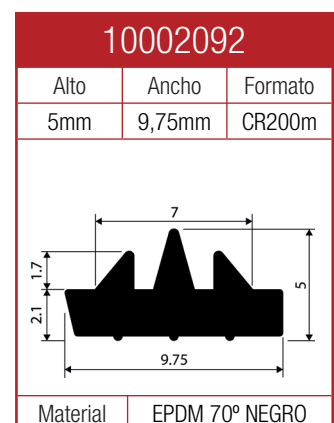
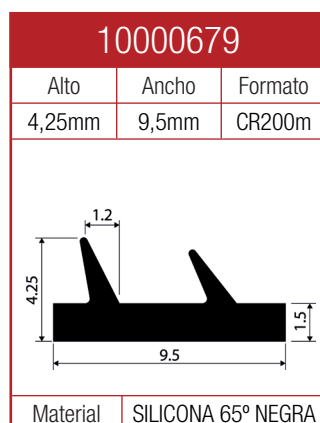
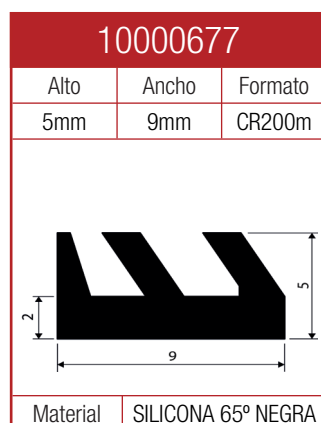
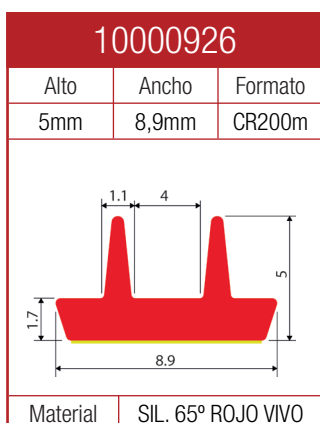
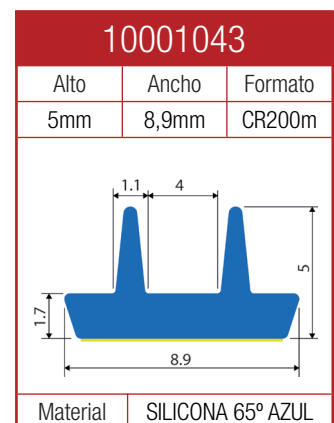
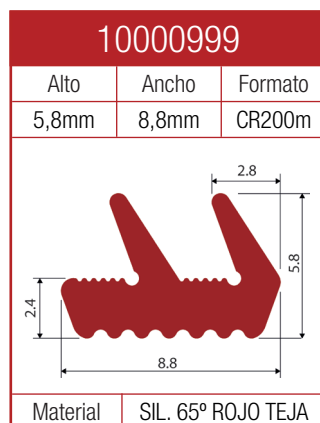
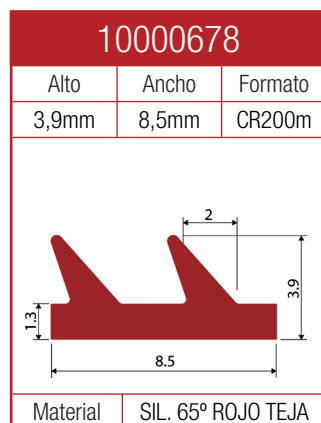
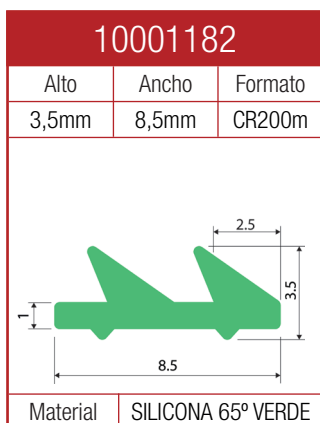
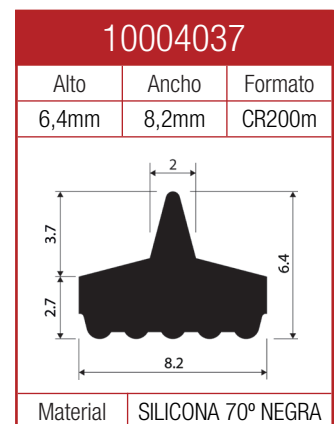
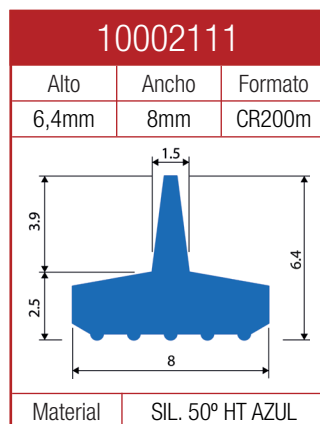
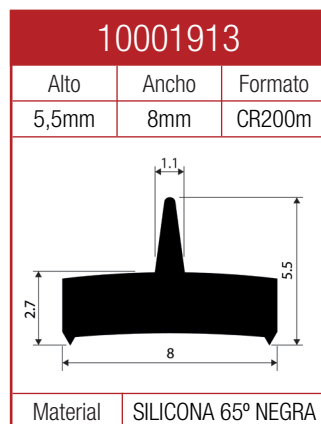
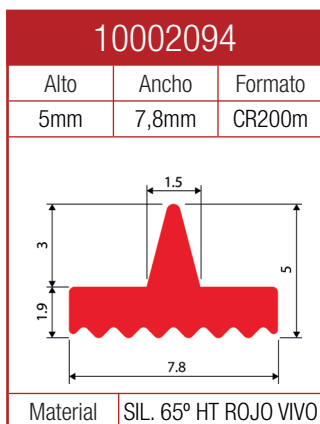
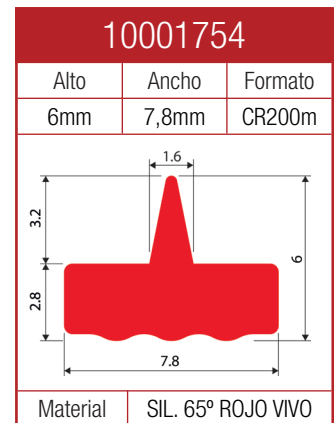
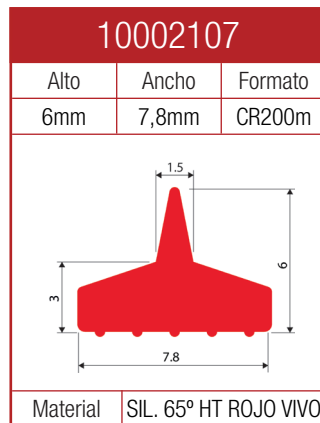
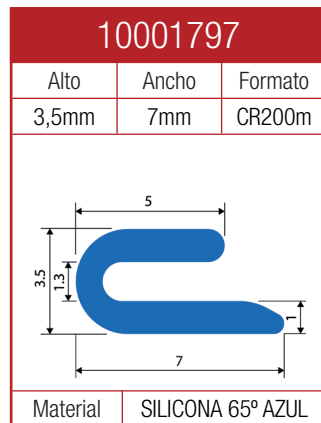
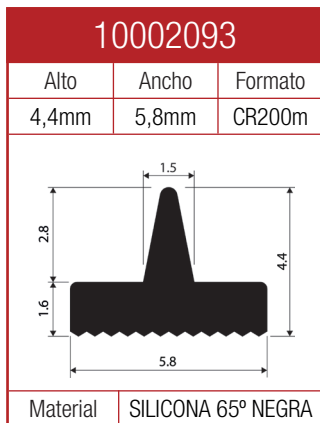



10004139

Alto	Ancho	Formato
6,2mm	9,8mm	CR200m

Material	SILICONA 70° GRIS
----------	-------------------

10000532

Alto	Ancho	Formato
6,5mm	10mm	CR200m

Material	SIL. 65° ROJO TEJA
----------	--------------------

10000680

Alto	Ancho	Formato
4,1mm	10mm	CR200m

Material	SILICONA 65° NEGRA
----------	--------------------

10001740

Alto	Ancho	Formato
5mm	10mm	CR200m

Material	SILICONA 65° VERDE
----------	--------------------

10003663

Alto	Ancho	Formato
6mm	10mm	CR200m

Material	SILICONA 65° GRIS
----------	-------------------

10003416

Alto	Ancho	Formato
6,2mm	10mm	CR200m

Material	SILICONA 65° VERDE
----------	--------------------

10001212

Alto	Ancho	Formato
7,5mm	10mm	CR200m

Material	SILICONA 65° NEGRA
----------	--------------------

10004024

Alto	Ancho	Formato
5,9mm	10,57mm	CR200m

Material	SILICONA 70° GRIS
----------	-------------------

10004025

Alto	Ancho	Formato
5,9mm	10,57mm	CR200m

Material	EPDM 60° NEGRO
----------	----------------

10001743

Alto	Ancho	Formato
7,2mm	11,2mm	CR200m

Material	SILICONA 65° NEGRA
----------	--------------------

100H1369

Alto	Ancho	Formato
4mm	11,7mm	CR200

Material	SILICONA 70° NEGRO
----------	--------------------

10001558

Alto	Ancho	Formato
6mm	12mm	CR200m

Material	SILICONA 65° GRIS
----------	-------------------

10001771

Alto	Ancho	Formato
6,5mm	12mm	CR200m

Material	SIL. 65° ROJO TEJA
----------	--------------------

10001508

Alto	Ancho	Formato
7,5mm	12mm	CR200m

Material	EPDM 70° NEGRO
----------	----------------

10003124

Alto	Ancho	Formato
6,5mm	19,9mm	CR200m

Material	SILICONA 65° NEGRA
----------	--------------------

10001514

Alto	Ancho	Formato
6,7mm	27mm	CR200m

Material	SILICONA 65° NEGRA
----------	--------------------



EPDM / VMQ

JUNTAS DE EVACUACIÓN DE GASES Y HUMOS

10004660

Alto	Ancho	Formato
10,4mm	30,8mm	CR75m

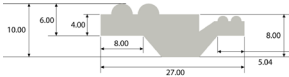

Material	SILICONA. 70° GRIS
----------	--------------------



EPDM / VMQ

JUNTAS PARA TUBERÍAS, TUBOS Y SISTEMA DE VENTILACIÓN

10003946

Alto	Ancho	Formato
10,4mm	30,8mm	CR200m

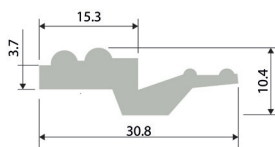

Material	SILICONA. 65° GRIS
----------	--------------------

10003328

Alto	Ancho	Formato
7,6mm	20mm	CR200m



Material	SIL. 65° ROJO TEJA
----------	--------------------

1003460

Regata	Alto	Formato
5mm	6,1mm	CR200m

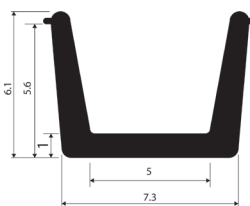

Material	EPDM 70° NEGRO
----------	----------------

A- 165

Alto	Ancho	Formato
6mm	11,8mm	CR200m

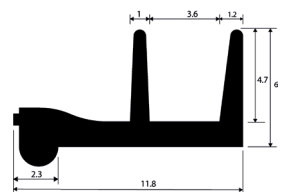

Material	EPDM 70° NEGRO
----------	----------------

A- 166

Alto	Ancho	Formato
9mm	11mm	CR200m

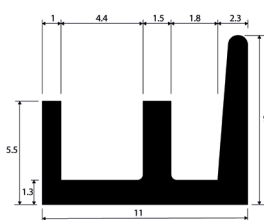

Material	EPDM 70° NEGRO
----------	----------------

A- 167

Alto	Ancho	Formato
14,3mm	14,5mm	CR200m

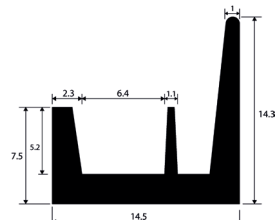

Material	EPDM 70° NEGRO
----------	----------------

A- 168

Alto	Ancho	Formato
19mm	15,5mm	CR200m

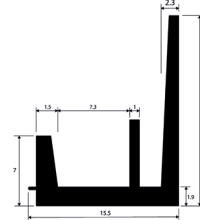

Material	EPDM 70° NEGRO
----------	----------------

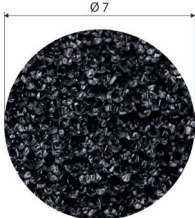
B- 129		
Diámetro	Color	Formato
7mm	Negro	Juntas
		
Material	ESP-EPDM 0.60°	

B- 130		
Diámetro	Color	Formato
8mm	Negro	Juntas
		
Material	ESP-EPDM 0.60°	

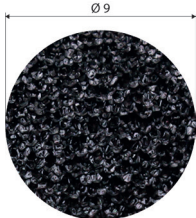
B- 131		
Diámetro	Color	Formato
9mm	Negro	Juntas
		
Material	ESP-EPDM 0.60°	

B- 132		
Diámetro	Color	Formato
10mm	Negro	Juntas
		
Material	ESP-EPDM 0.60°	

B- 133		
Diámetro	Color	Formato
11mm	Negro	Juntas
		
Material	ESP-EPDM 0.60°	

B- 134		
Diámetro	Color	Formato
12mm	Negro	Juntas
		
Material	ESP-EPDM 0.60°	

B- 135		
Diámetro	Color	Formato
13mm	Negro	Juntas
		
Material	ESP-EPDM 0.60°	

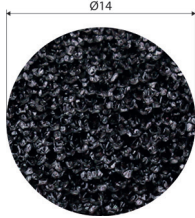
B- 136		
Diámetro	Color	Formato
14mm	Negro	Juntas
		
Material	ESP-EPDM 0.60°	

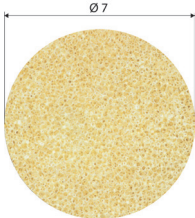
B- 137		
Diámetro	Color	Formato
7mm	Beige	Juntas
		
Material	ESP-EPDM 0.60°	

B- 138		
Diámetro	Color	Formato
8mm	Beige	Juntas
		
Material	ESP-EPDM 0.60°	

B- 139		
Diámetro	Color	Formato
9mm	Beige	Juntas
		
Material	ESP-EPDM 0.60°	

B- 140		
Diámetro	Color	Formato
10mm	Beige	Juntas
		
Material	ESP-EPDM 0.60°	

B- 141		
Diámetro	Color	Formato
11mm	Beige	Juntas
		
Material	ESP-EPDM 0.60°	

B- 142		
Diámetro	Color	Formato
12mm	Beige	Juntas
		
Material	ESP-EPDM 0.60°	

B- 143		
Diámetro	Color	Formato
13mm	Beige	Juntas
		
Material	ESP-EPDM 0.60°	

B- 144		
Diámetro	Color	Formato
14mm	Beige	Juntas
		
Material	ESP-EPDM 0.60°	



A- 137

Alto	Ancho	Formato
11,3mm	18mm	Juntas

Material	ESP-EPDM 0.60°
----------	----------------

A- 138

Alto	Ancho	Formato
19,3mm	26mm	Juntas

Material	ESP-EPDM 0.60°
----------	----------------

A- 139

Alto	Ancho	Formato
7,3mm	14mm	Juntas

Material	ESP-EPDM 0.60°
----------	----------------

10003379

Alto	Ancho	Formato
13,7mm	14mm	Juntas

Material	ESP-EPDM 0.65°
----------	----------------

100H1500

Alto	Ancho	Formato
10mm	15mm	Juntas

Material	ESP-EPDM 70° NEGRO
----------	--------------------

10003855

Alto	Ancho	Formato
13mm	20mm	Juntas

Material	ESP-EPDM 0.60°
----------	----------------

A- 135

Alto	Ancho	Formato
15,3mm	22mm	Juntas

Material	ESP-EPDM 0.60°
----------	----------------

10003647

Alto	Ancho	Formato
14,1mm	20,5mm	Juntas

Material	ESP-EPDM 0.65°
----------	----------------

A- 136

Alto	Ancho	Formato
15,3mm	22mm	Juntas

Material	ESP-EPDM 0.60°
----------	----------------

10003368

Alto	Ancho	Formato
9mm	15,5mm	Juntas

Material	ESP-EPDM 0.65°
----------	----------------

10003886

Alto	Ancho	Formato
12,7mm	12,2mm	Juntas

Material	EPDM CED. 0,65°
----------	-----------------

10003790

Alto	Ancho	Formato
6mm	4mm	Juntas

Material	EPDM 70° NEGRO
----------	----------------

10003125

Alto	Ancho	Formato
12mm	11mm	Juntas

Material	ESP-EPDM 0.55°
----------	----------------

10000713

Alto	Ancho	Formato
6mm	12mm	Juntas

Material	ESP-EPDM 0.55°
----------	----------------

10000715

Alto	Ancho	Formato
7mm	15mm	Juntas

Material	ESP-EPDM 0.55°
----------	----------------

10001087

Alto	Ancho	Formato
8mm	15mm	Juntas

Material	ESP-EPDM 0.55°
----------	----------------

10003055

Alto	Ancho	Inflado
32mm	35mm	38mm

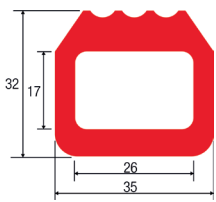

Presión min.	Presión rec.	Presión max.
10 PSI	15 PSI	18 PSI

A- 115

Alto	Ancho	Inflado
32mm	34,4mm	38mm

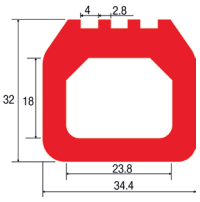

Presión min.	Presión rec.	Presión max.
10 PSI	15 PSI	18 PSI

A- 116

Alto	Ancho	Inflado
15mm	25,4mm	19mm

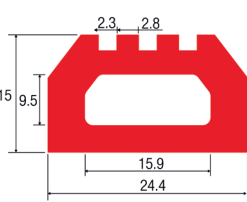

Presión min.	Presión rec.	Presión max.
10 PSI	15 PSI	20 PSI

A- 117

Alto	Ancho	Inflado
22,5mm	28,5mm	25,5mm

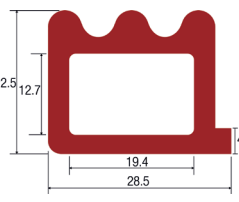

Presión min.	Presión rec.	Presión max.
8 PSI	10 PSI	12 PSI

A- 118

Alto	Ancho	Inflado
12,3mm	16,2mm	14mm

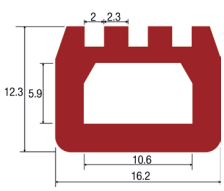

Presión min.	Presión rec.	Presión max.
10 PSI	15 PSI	20 PSI

A-119

Alto	Ancho	Inflado
11,5mm	15mm	13,5mm

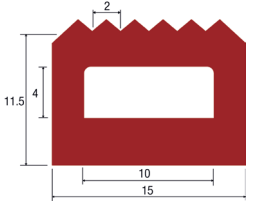

Presión min.	Presión rec.	Presión max.
10 PSI	15 PSI	20 PSI

A-120

Alto	Ancho	Inflado
23,3mm	50mm	41mm

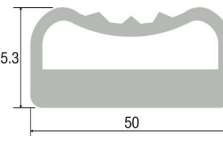

Presión min.	Presión rec.	Presión max.
8 PSI	10 PSI	13 PSI

A-121

Alto	Ancho	Inflado
28mm	40mm	34mm

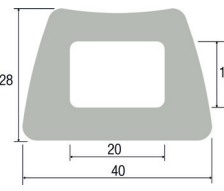

Presión min.	Presión rec.	Presión max.
20 PSI	25 PSI	35 PSI

A- 122

Alto	Ancho	Inflado
28mm	25,3mm	37mm

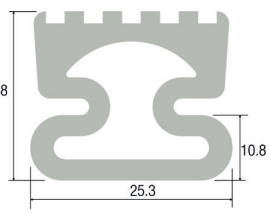

Presión min.	Presión rec.	Presión max.
8 PSI	10 PSI	15 PSI

A-123

Alto	Ancho	Inflado
7mm	16,9mm	11mm

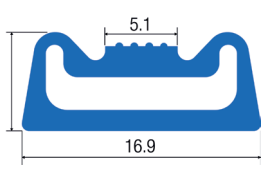

Presión min.	Presión rec.	Presión max.
8 PSI	12 PSI	16 PSI

A-124

Alto	Ancho	Inflado
24,4mm	25,3mm	37mm

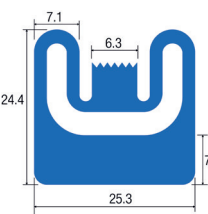

Presión min.	Presión rec.	Presión max.
15 PSI	20 PSI	25 PSI

A-125

Alto	Ancho	Inflado
11,7mm	20,5mm	18mm

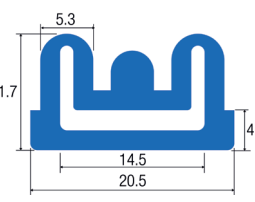

Presión min.	Presión rec.	Presión max.
10 PSI	15 PSI	20 PSI

A-126

Alto	Ancho	Inflado
10,1mm	14,5mm	15mm

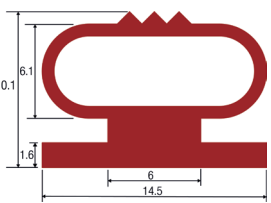

Presión min.	Presión rec.	Presión max.
8 PSI	10 PSI	15 PSI

A-127

Alto	Ancho	Inflado
23mm	51,4mm	42mm

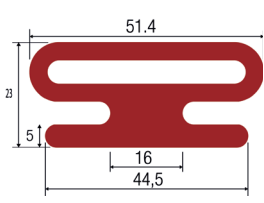

Presión min.	Presión rec.	Presión max.
15 PSI	20 PSI	25 PSI

A-128

Alto	Ancho	Inflado
13mm	14mm	23mm

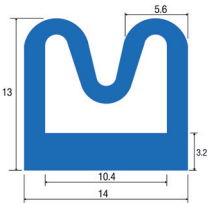

Presión min.	Presión rec.	Presión max.
10 PSI	20 PSI	25 PSI



10001994

Alto	Ancho	Formato
7mm	12mm	CR100m

Material EPDM 70° BLANCO

10001784

Alto	Ancho	Formato
7mm	12mm	CR75m

Material FKM 70° NEGRO

10001536

Alto	Ancho	Formato
7mm	12,2mm	R50m

Material NBR 70° NEGRO

10001605

Alto	Ancho	Formato
7mm	12,2mm	R50m

Material EPDM 70° NEGRO

A- 114

Alto	Ancho	Formato
7mm	12,2mm	R50m

Material SIL. 65° TRANS.

10002748

Alto	Ancho	Formato
9mm	23mm	CR50m

Material EPDM 70° NEGRO



10003393

Regata	Ancho	Formato
1,6mm	12,2mm	CR50m

Material	EPDM 70° - CEDULAR
----------	--------------------

10003394

Regata	Ancho	Formato
4mm	23mm	CR50m

Material	EPDM 70° - CEDULAR
----------	--------------------

10003395

Regata	Ancho	Formato
4,2mm	22mm	CR100m

Material	EPDM 70° - CEDULAR
----------	--------------------

10003396

Regata	Ancho	Formato
4,5mm	16,1mm	CR50m

Material	EPDM 70° - CEDULAR
----------	--------------------

10003397

Regata	Ancho	Formato
5,5mm	26mm	CR50m

Material	EPDM 70° - CEDULAR
----------	--------------------

10003398

Regata	Ancho	Formato
8,3mm	31mm	CR50m

Material	EPDM 70° - CEDULAR
----------	--------------------

10003399

Regata	Ancho	Formato
1,8mm	8,3mm	CR100m

Material	EPDM 70° - CEDULAR
----------	--------------------

10003400

Regata	Ancho	Formato
3,3mm	8mm	CR50m

Material	EPDM 70° - CEDULAR
----------	--------------------

10003401

Regata	Ancho	Formato
6mm	16mm	CR50m

Material	EPDM 70° - CEDULAR
----------	--------------------

10003402

Regata	Ancho	Formato
6,5mm	19,8mm	CR50m

Material	EPDM 70° - CEDULAR
----------	--------------------

10003403

Regata	Ancho	Formato
7mm	13mm	CR100m

Material	EPDM 70° - CEDULAR
----------	--------------------

10003404

Regata	Ancho	Formato
7mm	19mm	CR50m

Material	EPDM 70° - CEDULAR
----------	--------------------

10003405

Regata	Ancho	Formato
3,5mm	10mm	CR50m

Material	EPDM 70° - CEDULAR
----------	--------------------

10003406

Regata	Ancho	Formato
5mm	10mm	CR50m

Material	EPDM 70° - CEDULAR
----------	--------------------

10003407

Regata	Ancho	Formato
6mm	19,4mm	CR100m

Material	EPDM 70° - CEDULAR
----------	--------------------

10000707

Regata	Ancho	Formato
20mm	23mm	CR100m

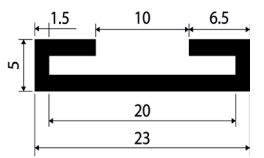

Material	EPDM 70° NEGRO
----------	----------------

10000708

Regata	Ancho	Formato
22mm	25mm	CR100m

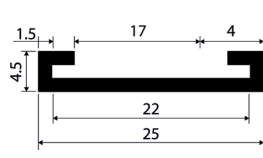

Material	EPDM 70° NEGRO
----------	----------------

10001968

Regata	Ancho	Formato
22,5mm	25mm	R100m

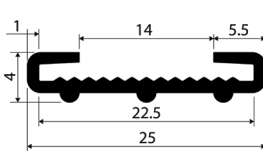

Material	EPDM 70° NEGRO
----------	----------------

10001817

Regata	Ancho	Formato
21,1mm	25,5mm	CR50m

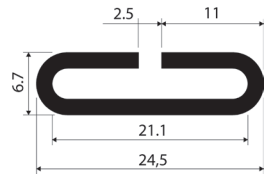

Material	EPDM 70° NEGRO
----------	----------------

10000706

Regata	Ancho	Formato
22mm	26mm	CR100m

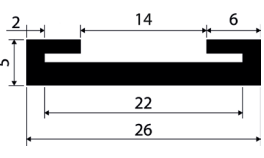

Material	EPDM 70° NEGRO
----------	----------------

10003968

Regata	Ancho	Formato
22,1mm	26,7mm	CR100m

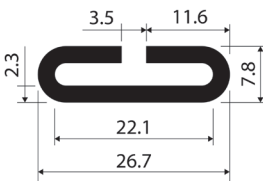

Material	EPDM 70° NEGRO
----------	----------------

10002574

Regata	Ancho	Formato
30mm	32,4mm	R100m

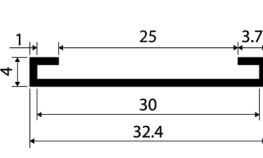

Material	EPDM 70° NEGRO
----------	----------------

A- 169

Regata	Ancho	Formato
29mm	33mm	CR50m

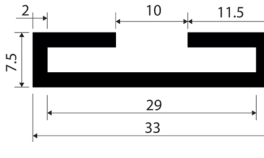

Material	EPDM 70° NEGRO
----------	----------------

10001668

Regata	Ancho	Formato
30,5mm	34,1mm	CR50m

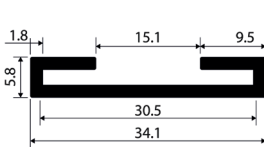

Material	EPDM 70° NEGRO
----------	----------------

10002478

Regata	Ancho	Formato
30,5mm	34,5mm	CR50m

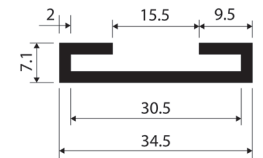

Material	EPDM 70° NEGRO
----------	----------------

10002762

Regata	Ancho	Formato
30mm	35mm	CR50m

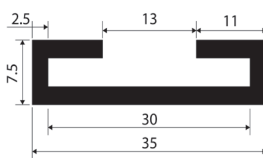

Material	EPDM 70° NEGRO
----------	----------------

10002653

Regata	Ancho	Formato
30mm	35,6mm	R50m

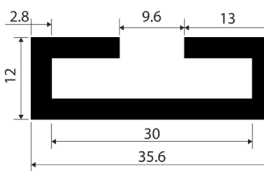

Material	EPDM 70° NEGRO
----------	----------------

10000903

Regata	Ancho	Formato
40,4mm	44mm	R50m

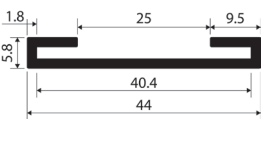

Material	EPDM 70° NEGRO
----------	----------------

10001667

Regata	Ancho	Formato
50mm	54mm	CR50m

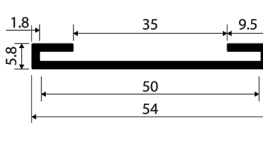

Material	EPDM 70° NEGRO
----------	----------------

10003550

Regata	Ancho	Formato
36,5mm	61mm	R25m

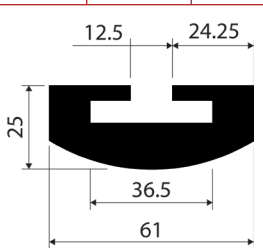

Material	EPDM 70° NEGRO
----------	----------------



10003415

Alto	Ancho	Formato
9mm	13mm	R100m

Material	EPDM 70° NEGRO
----------	----------------

10003167

Alto	Ancho	Formato
19mm	18mm	R50m

Material	EPDM IGN 70° NEGRO
----------	--------------------

10001685

Alto	Ancho	Formato
11,5mm	206mm	R50m

Material	EPDM 70° NEGRO
----------	----------------

10002603

Alto	Ancho	Formato
21mm	29mm	CR25m

Material	SILICONA 65° NEGRO
----------	--------------------

10002469

Alto	Ancho	Formato
10,16mm	30mm	R50m

Material	EPDM 70° NEGRO
----------	----------------

10003012

Alto	Ancho	Formato
18,5mm	29mm	R50m

Material	EPDM 70° NEGRO
----------	----------------

10002986

Alto	Ancho	Formato
12mm	30mm	CR50m

Material	EPDM 70° NEGRO
----------	----------------

10003122

Alto	Ancho	Formato
17,5mm	33,6mm	R50m

Material	EPDM 70° NEGRO
----------	----------------

10001560

Alto	Ancho	Formato
20mm	34mm	R50m

Material	EPDM 70° NEGRO
----------	----------------

10002559

Alto	Ancho	Formato
21mm	38mm	R50m

Material	EPDM 70° NEGRO
----------	----------------

10000887

Alto	Ancho	Formato
8,04mm	9,24mm	CR100m

Material	EPDM 70° NEGRO
----------	----------------

10000964

Alto	Ancho	Formato
15mm	20mm	CR50m

Material	EPDM 70° NEGRO
----------	----------------

10003134

Alto	Ancho	Formato
30mm	25mm	CR50m

Material	EPDM 70° NEGRO
----------	----------------

10000946

Alto	Ancho	Formato
20mm	29,5mm	CR25m

Material	EPDM 70° NEGRO
----------	----------------

10000475

Alto	Ancho	Formato
17,5mm	22,9mm	CR50m

Material	NBR 70° NEGRO
----------	---------------

10000888

Alto	Ancho	Formato
19,2mm	24mm	CR50m

Material	EPDM 70° NEGRO
----------	----------------



10003905		
Alto	Ancho	Formato
11mm	7,9mm	CR100m
Material	EPDM 70° NEGRO	

10002796		
Alto	Ancho	Formato
13,15mm	9,15mm	CR200m
Material	EPDM 70° NEGRO	

10002797		
Alto	Ancho	Formato
9,7mm	9,4mm	CR200m
Material	EPDM 70° NEGRO	

10003906		
Alto	Ancho	Formato
9,3mm	7,5mm	CR100m
Material	EPDM 70° NEGRO	

10003363		
Alto	Ancho	Formato
9.2mm	10.5mm	CR200m
Material	EPDM 70° NEGRO	

10003908		
Alto	Ancho	Formato
10,4mm	7,8mm	CR100m
Material	EPDM 70° NEGRO	

10003907		
Alto	Ancho	Formato
11,3mm	8,4mm	CR100m
Material	EPDM 70° NEGRO	

10003362		
Alto	Ancho	Formato
12,5mm	13mm	CR200m
Material	EPDM 70° NEGRO	

10003193		
Alto	Ancho	Formato
4mm	9mm	CR200m
Material	EPDM 70° NEGRO	

10002676		
Alto	Ancho	Formato
14mm	12mm	CR100m
Material	EPDM 70° NEGRO	

10003378		
Alto	Ancho	Formato
12,5mm	13mm	CR100m
Material	EPDM 50° NEGRO	

10001875		
Alto	Ancho	Formato
16,8mm	14mm	CR100m
Material	EPDM 70° NEGRO	

10002580		
Alto	Ancho	Formato
10,2mm	14,3mm	R100m
Material	EPDM 70° NEGRO	

10004584 *		
Alto	Ancho	Formato
17.32mm	18mm	CR50
Material	EPDM 70° NEGRO	

10004638 *		
Alto	Ancho	Formato
21.36mm	19.55mm	CR50
Material	ESP-EPDM 0,80°	

10004661 *		
Alto	Ancho	Formato
8.04mm	12.44mm	CR150
Material	EPDM 70° NEGRO	



10004302

Alto	Ancho	Formato
19,5mm	26,3mm	CR50m

Material	EPDM 70° NEGRO
----------	----------------

PERFILES PARA CARROCERÍAS EPDM / TPE / TPV



A- 100

Alto	Ancho	Formato
70mm	52mm	TIRAS

Material	RÍGIDO-TPV 60°
----------	----------------

A- 101

Alto	Ancho	Formato
51,8mm	52mm	TIRAS

Material	RÍGIDO-TPV 60°
----------	----------------

A- 102

Alto	Ancho	Formato
60mm	73,5mm	TIRAS

Material	RÍGIDO-TPV 60°
----------	----------------

A- 103

Alto	Ancho	Formato
44mm	75,2mm	TIRAS

Material	EPDM 70° NEGRO
----------	----------------

A- 104

Alto	Ancho	Formato
43mm	84mm	TIRAS

Material	EPDM 70° NEGRO
----------	----------------

A- 105

Alto	Ancho	Formato
48mm	106mm	TIRAS

Material	EPDM 70° NEGRO
----------	----------------

100H1571

Alto	Ancho	Formato
46,5mm	95mm	TIRAS

Material	EPDM 70° NEGRO
----------	----------------

100H1572

Alto	Ancho	Formato
46,5mm	95,6mm	TIRAS

Material	EPDM 70° NEGRO
----------	----------------



EPDM / VMQ PERFILES PARA CONTAINER BASURA

10002141

Alto	Ancho	Formato
26mm	22mm	R25m

Material	EPDM 70° NEGRO
----------	----------------

10003137

Alto	Ancho	Formato
28,4mm	25,5mm	R30m

Material	EPDM 70° NEGRO
----------	----------------

10002181

Alto	Ancho	Formato
28,5mm	28mm	R30m

Material	EPDM 70° NEGRO
----------	----------------

10000973

Alto	Ancho	Formato
21,2mm	33,5mm	R25m

Material	EPDM 70° NEGRO
----------	----------------

10002144

Alto	Ancho	Formato
24mm	35mm	R25m

Material	EPDM 70° NEGRO
----------	----------------

10000978

Alto	Ancho	Formato
30mm	38mm	R25m

Material	EPDM 70° NEGRO
----------	----------------

10003683

Alto	Ancho	Formato
30mm	38mm	R25m

Material	SIL. 70° TRANS.
----------	-----------------

10002126

Alto	Ancho	Formato
30mm	38mm	R28m

Material	EPDM 70° NEGRO
----------	----------------

10002125

Alto	Ancho	Formato
30mm	38mm	R25m

Material	EPDM 50° NEGRO
----------	----------------

10003643

Alto	Ancho	Formato
38,9mm	48mm	R25m

Material	EPDM 70° NEGRO
----------	----------------



A- 106

Alto	Ancho	Formato
23,5mm	18mm	CR50m

Material	EPDM 70° - CEDULAR
----------	--------------------

A- 107

Alto	Ancho	Formato
8,6mm	7mm	CR100m

Material	EPDM 70° - CEDULAR
----------	--------------------

A- 108

Alto	Ancho	Formato
7,5mm	7,2mm	CR100m

Material	EPDM 70° - CEDULAR
----------	--------------------

A- 109

Alto	Ancho	Formato
8,7mm	12mm	CR100m

Material	EPDM 70° - CEDULAR
----------	--------------------

100H1395

Alto	Ancho	Formato
7mm	7mm	CR100m

Material	EPDM 70° - CEDULAR
----------	--------------------

100H1394

Alto	Ancho	Formato
18mm	15mm	CR100m

Material	EPDM 70° - CEDULAR
----------	--------------------



EPDM

DEFENSAS

10003358

Alto	Ancho	Formato
45mm	45mm	R25m

Material	EPDM 70° NEGRO
----------	----------------

10003357

Alto	Ancho	Formato
70mm	80mm	TIRAS

Material	EPDM 70° NEGRO
----------	----------------

10004044

Alto	Ancho	Formato
49mm	38mm	TIRAS

Material	EPDM 70° NEGRO
----------	----------------

10002348

Alto	Ancho	Formato
33,5mm	32,4mm	R25m

Material	EPDM 70° NEGRO
----------	----------------

10002408

Alto	Ancho	Formato
38mm	37mm	R25m

Material	EPDM 70° NEGRO
----------	----------------

10002095

Alto	Ancho	Formato
37,6mm	39mm	TIRAS

Material	EPDM 70° GRIS
----------	---------------

10001949

Alto	Ancho	Formato
45mm	45mm	R25m

Material	EPDM 70° NEGRO
----------	----------------

10004186

Alto	Ancho	Formato
60mm	50mm	TIRAS

Material	EPDM 70° NEGRO
----------	----------------

10003097

Alto	Ancho	Formato
45mm	50mm	R25m

Material	EPDM 70° NEGRO
----------	----------------

10003497

Alto	Ancho	Formato
70mm	65mm	R25m

Material	EPDM 70° NEGRO
----------	----------------

10003132

Alto	Ancho	Formato
64mm	70mm	TIRAS

Material	EPDM 70° NEGRO
----------	----------------

10003785

Alto	Ancho	Formato
70mm	80mm	TIRAS

Material	EPDM 70° NEGRO
----------	----------------

10003359

Alto	Ancho	Formato
80mm	80mm	TIRAS

Material	EPDM 70° NEGRO
----------	----------------

10003776

Alto	Ancho	Formato
95mm	100mm	TIRAS

Material	EPDM 70° NEGRO
----------	----------------

10004242

Alto	Ancho	Formato
80mm	120mm	TIRAS

Material	EPDM 70° NEGRO
----------	----------------

10004005

Alto	Ancho	Formato
120mm	120mm	TIRAS

Material	EPDM 70° NEGRO
----------	----------------



10002628		
Alto	Ancho	Formato
15mm	15,5mm	CR50m
Material	EPDM 70° NEGRO	

10002629		
Alto	Ancho	Formato
15mm	15,5mm	CR50m
Material	SIL. 70° ROJO VIVO	

10001632		
Alto	Ancho	Formato
14,5mm	16,5mm	CR50m
Material	EPDM 70° NEGRO	

10001633		
Alto	Ancho	Formato
14,5mm	16,5mm	CR50m
Material	SIL. 65° TRANS.	

10002626		
Alto	Ancho	Formato
13mm	17mm	CR50m
Material	EPDM 70° NEGRO	

10002627		
Alto	Ancho	Formato
13mm	17mm	CR50m
Material	SIL. 70° ROJO VIVO	

10001147		
Alto	Ancho	Formato
15mm	16mm	CR75m
Material	EPDM 70° NEGRO	

10000196		
Alto	Ancho	Formato
17mm	18,5mm	CR50m
Material	SIL. 65° GRIS	

10001143		
Alto	Ancho	Formato
17mm	18,5mm	CR50m
Material	EPDM 70° NEGRO	

10001616		
Alto	Ancho	Formato
17mm	18,5mm	CR50m
Material	SIL. 70° ROJO VIVO	

10003541		
Alto	Ancho	Formato
18mm	17,5mm	CR50m
Material	EPDM CED. 0,65°	

10003547		
Alto	Ancho	Formato
15,5mm	15mm	R50m
Material	EPDM CED. 0,65°	

10004333		
Alto	Ancho	Formato
15mm	10mm	CR100m
Material	EPDM 70° NEGRO	

10002654

Alto	Ancho	Formato
4,25mm	7,25mm	CR200m

Material EPDM 70° NEGRO

10002380

Alto	Ancho	Formato
10mm	10mm	CR100m

Material EPDM 70° NEGRO

10000733

Alto	Ancho	Formato
10mm	15mm	CR100m

Material EPDM 70° GRIS

10002953

Alto	Ancho	Formato
10mm	15mm	CR100m

Material EPDM 70° GRIS

10003757

Alto	Ancho	Formato
27mm	15,3mm	CR100m

Material SILICONA 70° NEGRO

10003733

Alto	Ancho	Formato
18mm	17,5mm	CR100

Material EPDM 70° NEGRO

10003970

Alto	Ancho	Formato
5mm	18mm	CR100m

Material EPDM 0,65° NEGRO

10000201

Alto	Ancho	Formato
20mm	20mm	CR100m

Material EPDM 70° NEGRO

10000734

Alto	Ancho	Formato
20mm	20mm	CR50m

Material EPDM 70° NEGRO

10001241

Alto	Ancho	Formato
22mm	22mm	CR100m

Material NEOPRENO 70° GRIS

10002116

Alto	Ancho	Formato
17,5mm	24,5mm	R50m

Material EPDM 70° NEGRO

10003920

Alto	Ancho	Formato
25mm	25mm	CR50m

Material EPDM 70° NEGRO

10000735

Alto	Ancho	Formato
30mm	30mm	CR50m

Material EPDM 70° NEGRO

10002939

Alto	Ancho	Formato
30mm	30mm	CR50m

Material EPDM 70° BLANCO

10003522

Alto	Ancho	Formato
35mm	35mm	R50m

Material EPDM 70° NEGRO

10000898

Alto	Ancho	Formato
13mm	37,14mm	R100m

Material EPDM 70° NEGRO

10002117

Alto	Ancho	Formato
40mm	40mm	R12m

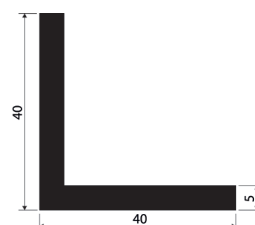

Material	EPDM 70° NEGRO
----------	----------------

10004041

Alto	Ancho	Formato
50mm	50mm	TIRAS

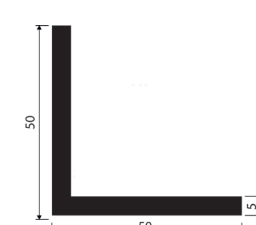

Material	EPDM 70° NEGRO
----------	----------------

10002488

Alto	Ancho	Formato
35mm	55mm	R25m

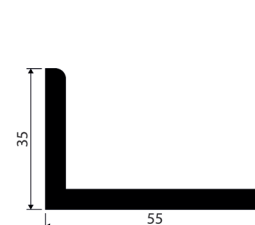

Material	EPDM 70° NEGRO
----------	----------------

10001263

Alto	Ancho	Formato
38mm	55mm	CR100m

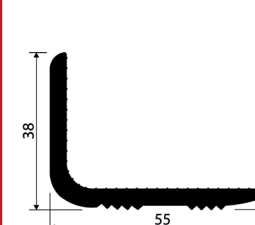

Material	EPDM 70° NEGRO
----------	----------------

10002622

Alto	Ancho	Formato
42mm	69mm	R50m

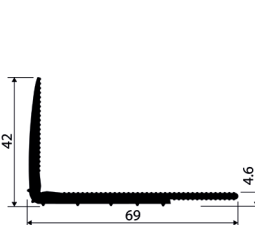

Material	EPDM 70° NEGRO
----------	----------------

10003681

Alto	Ancho	Formato
63mm	105mm	CR200m

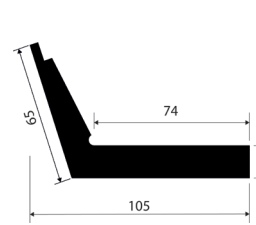

Material	EPDM 65° NEGRO
----------	----------------

10002460

Alto	Ancho	Formato
75mm	150mm	R10m

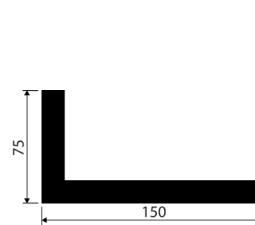

Material	EPDM 70° NEGRO
----------	----------------

10004657 *

Alto	Ancho	Formato
15mm	20mm	CR100m

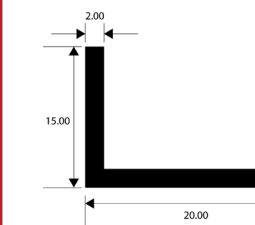

Material	EPDM IGN NEGRO
----------	----------------

10004698 *

Alto	Ancho	Formato
10mm	20mm	CR100m

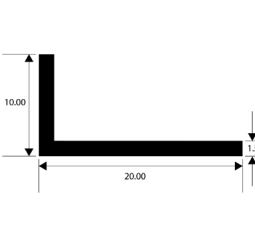

Material	EPDM 70° NEGRO
----------	----------------



10000737

Alto	Ancho	Formato
7mm	7mm	CR100m

Material	EPDM 70° NEGRO
----------	----------------

10000540

Alto	Ancho	Formato
10mm	8mm	CR100m

Material	EPDM 70° BLANCO
----------	-----------------

10000505

Alto	Ancho	Formato
13mm	8mm	CR100m

Material	EPDM 70° NEGRO
----------	----------------

10002959 ADH

Alto	Ancho	Formato
5mm	8,5mm	CR200m

Material	EPDM 48° GRIS
----------	---------------

10000738

Alto	Ancho	Formato
13mm	9,5mm	CR100m

Material	EPDM 70° NEGRO
----------	----------------

10000549

Alto	Ancho	Formato
15mm	13mm	CR50m

Material	EPDM 70° NEGRO
----------	----------------

10000770

Alto	Ancho	Formato
16mm	10mm	CR50m

Material	EPDM 70° NEGRO
----------	----------------

10004330

Alto	Ancho	Formato
5mm	10mm	CR200m

Material	EPDM 70° NEGRO
----------	----------------

10001912

Alto	Ancho	Formato
16mm	13mm	CR100m

Material	EPDM 70° NEGRO
----------	----------------

10001960

Alto	Ancho	Formato
25mm	10mm	CR50m

Material	EPDM 70° NEGRO
----------	----------------

10000769

Alto	Ancho	Formato
16mm	10,5mm	CR50m

Material	EPDM 70° NEGRO
----------	----------------

10002475

Alto	Ancho	Formato
12mm	12mm	CR50m

Material	SIL. 70° TRANS.
----------	-----------------

10000740

Alto	Ancho	Formato
14mm	12mm	CR100m

Material	EPDM 70° NEGRO
----------	----------------

10002780

Alto	Ancho	Formato
14mm	12mm	CR100m

Material	SILICONA 70° BLANCA
----------	---------------------

10003589

Alto	Ancho	Formato
14mm	12mm	CR50m

Material	EPDM 70° BLANCO
----------	-----------------

10000704

Alto	Ancho	Formato
7mm	13mm	CR100m

Material	EPDM 70° NEGRO
----------	----------------



10002544 ADH

Alto	Ancho	Formato
4,5mm	13mm	R100m

Material	EPDM 70° NEGRO
----------	----------------

10002543

Alto	Ancho	Formato
4,5mm	13mm	R100m

Material	EPDM 70° NEGRO
----------	----------------

10000741

Alto	Ancho	Formato
7mm	14mm	CR100m

Material	EPDM 70° NEGRO
----------	----------------

10000743

Alto	Ancho	Formato
8,5mm	14,5mm	CR50m

Material	EPDM 70° NEGRO
----------	----------------

10000739

Alto	Ancho	Formato
10mm	15mm	CR50m

Material	EPDM 70° NEGRO
----------	----------------

10003058

Alto	Ancho	Formato
12mm	15,5mm	CR200m

Material	EPDM 70° NEGRO
----------	----------------

10000345

Alto	Ancho	Formato
33,5mm	15,5mm	R50m

Material	EPDM 70° NEGRO
----------	----------------

10002123

Alto	Ancho	Formato
19mm	16mm	CR50m

Material	EPDM 70° NEGRO
----------	----------------

10000866

Alto	Ancho	Formato
16mm	17mm	R50m

Material	EPDM 70° NEGRO
----------	----------------

10000744

Alto	Ancho	Formato
11mm	17,5mm	CR50m

Material	EPDM 70° NEGRO
----------	----------------

10001786

Alto	Ancho	Formato
12mm	20mm	CR50m

Material	EPDM 70° NEGRO
----------	----------------

10000742

Alto	Ancho	Formato
10mm	20mm	CR50m

Material	EPDM 70° NEGRO
----------	----------------

10000274

Alto	Ancho	Formato
15mm	20mm	CR50m

Material	EPDM 70° NEGRO
----------	----------------

10000896

Alto	Ancho	Formato
20mm	20mm	R25m

Material	EPDM 70° BLANCO
----------	-----------------

10002098

Alto	Ancho	Formato
20mm	20mm	CR25m

Material	SIL. 65° ROJO VIVO
----------	--------------------

10003133

Alto	Ancho	Formato
50mm	25mm	R25m

Material	EPDM 70° NEGRO
----------	----------------



10003804

Alto	Ancho	Formato
11.5mm	26,5mm	R100m

Material	EPDM 70° NEGRO
----------	----------------

10003422

Alto	Ancho	Formato
40mm	37,5mm	R25m

Material	EPDM 70° NEGRO
----------	----------------

10003234

Alto	Ancho	Formato
20mm	40mm	R25m

Material	EPDM 70° NEGRO
----------	----------------

10004309

Alto	Ancho	Formato
29mm	40mm	R25m

Material	EPDM 65° NEGRO
----------	----------------

10001642

Alto	Ancho	Formato
24mm	42mm	CR25m

Material	EPDM 70° NEGRO
----------	----------------

10002433

Alto	Ancho	Formato
26mm	44mm	R30m

Material	EPDM 70° NEGRO
----------	----------------

10004656 *

Alto	Ancho	Formato
15mm	25mm	R50m

Material	EPDM 70° NEGRO
----------	----------------



10003179

Alto	Ancho	Formato
9mm	6mm	CR100m

Material	ESP-EPDM 0,65°
----------	----------------

10001036

Alto	Ancho	Formato
3,5mm	7mm	CR100m

Material	ESP-EPDM 0,85°
----------	----------------

10002199

Alto	Ancho	Formato
5mm	8mm	CR100m

Material	ESP-EPDM 0,85°
----------	----------------

10000714

Alto	Ancho	Formato
9mm	9mm	CR200m

Material	ESP-EPDM 0,60°
----------	----------------

10000710

Alto	Ancho	Formato
20mm	10mm	CR50m

Material	ESP-EPDM 0,60°
----------	----------------

10003125

Alto	Ancho	Formato
8mm	11mm	CR100m

Material	ESP-EPDM 0,55°
----------	----------------

10003778

Alto	Ancho	Formato
8mm	11mm	CR100m

Material	ESP-EPDM 0,60°
----------	----------------

10000713

Alto	Ancho	Formato
6mm	12mm	CR100m

Material	ESP-EPDM 0,55°
----------	----------------

10003816

Alto	Ancho	Formato
7mm	12mm	CR50

Material	ESP-EPDM 0,60°
----------	----------------

10002209

Alto	Ancho	Formato
10mm	12mm	CR50m

Material	ESP-EPDM 0,60°
----------	----------------

10000716

Alto	Ancho	Formato
17mm	12mm	CR50m

Material	ESP-EPDM 0,60°
----------	----------------

10003273

Alto	Ancho	Formato
8mm	13mm	CR100m

Material	ESP-EPDM 0,65°
----------	----------------

10000712 ADH

Alto	Ancho	Formato
7,9mm	14mm	CR100m

Material	ESP-EPDM 0,60°
----------	----------------

10001252

Alto	Ancho	Formato
7,9mm	14mm	CR100m

Material	ESP-EPDM 0,60°
----------	----------------

10002048

Alto	Ancho	Formato
29mm	14mm	CR50m

Material	ESP-EPDM 0,65°
----------	----------------

10001496

Alto	Ancho	Formato
7mm	15mm	CR100m

Material	ESP-EPDM 0,60°
----------	----------------



10000715			10002173 ADH			10001087			10001253 ADH		
Alto	Ancho	Formato	Alto	Ancho	Formato	Alto	Ancho	Formato	Alto	Ancho	Formato
7mm	15mm	CR100m	7mm	15mm	CR100m	8mm	15mm	CR50m	8mm	15mm	CR100m
Material	ESP-EPDM 0,55°		Material	ESP-EPDM 0,55°		Material	ESP-EPDM 0,55°		Material	ESP-EPDM 0,55°	
10003386			10002441			10002442 ADH			10001114		
Alto	Ancho	Formato	Alto	Ancho	Formato	Alto	Ancho	Formato	Alto	Ancho	Formato
9mm	15mm	CR100m	11mm	17,5mm	CR50m	11mm	17,5mm	CR50m	8mm	18mm	CR100m
Material	ESP-EPDM 0,65°		Material	ESP-EPDM 0,85°		Material	ESP-EPDM 0,85°		Material	ESP-EPDM 0,60°	
10001530			10002547			10002548 ADH			10000711		
Alto	Ancho	Formato	Alto	Ancho	Formato	Alto	Ancho	Formato	Alto	Ancho	Formato
12mm	18mm	CR100m	12,5mm	18mm	CR50m	12,5mm	18mm	CR50m	9,5mm	19mm	CR50m
Material	ESP-EPDM 0,55°		Material	ESP-EPDM 0,85°		Material	ESP-EPDM 0,85°		Material	ESP-EPDM 0,60°	
10003668			10000939			10002665			10002341 ADH		
Alto	Ancho	Formato	Alto	Ancho	Formato	Alto	Ancho	Formato	Alto	Ancho	Formato
24mm	19mm	CR25m	12mm	20mm	CR50m	10mm	20mm	CR50m	13,5mm	20,5mm	CR50m
Material	ESP-EPDM 0,65°		Material	ESP-EPDM 0,55°		Material	ESP-EPDM 0,55°		Material	ESP-EPDM 0,65°	



10001025

Alto	Ancho	Formato
13,5mm	20,5mm	CR50m

Material	ESP-EPDM 0,85°
----------	----------------

10003662

Alto	Ancho	Formato
23mm	22mm	CR25m

Material	ESP-EPDM 0,65°
----------	----------------

10002495

Alto	Ancho	Formato
20mm	30mm	CR25m

Material	ESP-EPDM 0,65°
----------	----------------

10003435

Alto	Ancho	Formato
30mm	30mm	R25m

Material	ESP-EPDM 0,65°
----------	----------------

10004629

Alto	Ancho	Formato
20mm	13mm	CR50

Material	ESP-EPDM 0,65°
----------	----------------

10004639 *

Alto	Ancho	Formato
13mm	20mm	CR50

Material	ESP-EPDM 0,60°
----------	----------------

10004605 *

Alto	Ancho	Formato
7mm	16mm	CR50

Material	ESP-EPDM 0,65°
----------	----------------



COLECTOR A		
Alto	Ancho	Tubo ext.
91mm	203mm	10,6mm
Material	DELRIN BLANCO	

COLECTOR B		
Alto	Ancho	Tubo ext.
57mm	150mm	9,6mm
Material	DELRIN BLANCO	

10000928		
Alto	Ancho	Formato
10mm	90mm	R30m
Material	EPDM 70° NEGRO	

A- 112		
Alto	Ancho	Formato
12mm	91,2mm	R37m
Material	EPDM 70° NEGRO	

A- 113		
Alto	Ancho	Formato
12mm	121,6mm	R37m
Material	EPDM 70° NEGRO	

10002758		
Alto	Ancho	Tubo ext.
12mm	182,4mm	R37m
Material	EPDM 70° NEGRO	



10000448

Alto	Ancho	Formato
8,1mm	6mm	CR100m

Material	SILICONA 65° GRIS
----------	-------------------

10000768

Alto	Ancho	Formato
8mm	8mm	CR50m

Material	EPDM 70° NEGRO
----------	----------------

10000767

Alto	Ancho	Formato
7mm	10mm	CR100m

Material	EPDM 70° NEGRO
----------	----------------

10000811

Alto	Ancho	Formato
3,5mm	10,8mm	R100m

Material	EPDM 70° NEGRO
----------	----------------

10000736

Alto	Ancho	Formato
10mm	15mm	CR100m

Material	EPDM 70° NEGRO
----------	----------------

10000397

Alto	Ancho	Formato
10mm	15mm	CR100m

Material	SIL. 70° TRANS.
----------	-----------------

10000683

Alto	Ancho	Formato
8mm	16mm	CR100m

Material	EPDM 70° NEGRO
----------	----------------

10004054

Alto	Ancho	Formato
8mm	20mm	CR50m

Material	EPDM 70° NEGRO
----------	----------------

10004349

Alto	Ancho	Formato
22mm	24mm	R50m

Material	EPDM 70° NEGRO
----------	----------------

10003285

Alto	Ancho	Formato
12mm	25mm	CR50m

Material	EPDM 70° NEGRO
----------	----------------

10003296

Alto	Ancho	Formato
38mm	30mm	R25m

Material	EPDM 70° NEGRO
----------	----------------

A- 170

Alto	Ancho	Formato
11mm	40mm	R25m

Material	EPDM 70° NEGRO
----------	----------------

10003768

Alto	Ancho	Formato
20mm	40mm	R25m

Material	EPDM 70° NEGRO
----------	----------------

10002845

Alto	Ancho	Formato
20mm	50mm	R25m

Material	EPDM IGN 70° NEGRO
----------	--------------------

10004334

Alto	Ancho	Formato
40mm	70mm	TIRAS

Material	EPDM 70° NEGRO
----------	----------------

10003242

Alto	Ancho	Formato
85mm	75mm	TIRAS

Material	EPDM 70° NEGRO
----------	----------------



EPDM / VMQ PERFILES FORMA T

10002846		
Alto	Ancho	Formato
20mm	80mm	R10m
Material	EPDM IGN 70° NEGRO	

10002517		
Alto	Ancho	Formato
40mm	80mm	R25m
Material	EPDM 70° NEGRO	

10002847		
Alto	Ancho	Formato
20mm	140mm	R5m
Material	EPDM IGN 70° NEGRO	

10004196		
Alto	Ancho	Formato
22,3mm	32,5mm	TIRAS
Material	EPDM 70° NEGRO	



EPDM / VMQ PERFILES OMEGA

10004696 *		
Alto	Ancho	Formato
16mm	15.5mm	CR75m
Material	ESP 65° - CEDULAR	

10004697 *		
Alto	Ancho	Formato
28mm	27mm	CR25m
Material	ESP 80° - CEDULAR	

10002956		
Alto	Ancho	Formato
16mm	16mm	CR50m
Material	ESP 60° NEGRO	

10002398		
Alto	Ancho	Formato
35,5mm	27mm	R30m
Material	EPDM 70° NEGRO	

10003072		
Alto	Ancho	Formato
30mm	25mm	R25m
Material	EPDM 70° NEGRO	



10003338

Alto	Ancho	Formato
8mm	9,5mm	CR100m

Material	EPDM 70° NEGRO
----------	----------------

10002359

Alto	Ancho	Formato
14mm	10mm	CR50m

Material	EPDM 70° NEGRO
----------	----------------

10000763

Alto	Ancho	Formato
5mm	10mm	CR100m

Material	EPDM 70° NEGRO
----------	----------------

10000761

Alto	Ancho	Formato
10mm	10mm	CR50m

Material	EPDM 70° NEGRO
----------	----------------

10000874

Alto	Ancho	Formato
7mm	11,5mm	CR100m

Material	EPDM 70° NEGRO
----------	----------------

10000747

Alto	Ancho	Formato
10mm	12mm	CR50m

Material	EPDM 70° NEGRO
----------	----------------

10000745

Alto	Ancho	Formato
14,5mm	12mm	CR50m

Material	EPDM 70° NEGRO
----------	----------------

10000899

Alto	Ancho	Formato
14,5mm	12mm	CR50m

Material	NBR 70° NEGRO
----------	---------------

10001818

Alto	Ancho	Formato
9mm	12mm	CR100m

Material	NBR 70° NEGRO
----------	---------------

10002215

Alto	Ancho	Formato
8,5mm	12,5mm	CR100m

Material	SIL. 65° TRANS.
----------	-----------------

10000326

Alto	Ancho	Formato
11mm	12,4mm	CR100m

Material	EPDM 70° NEGRO
----------	----------------

10002097

Alto	Ancho	Formato
10mm	13mm	CR100m

Material	EPDM 70° BLANCO
----------	-----------------

10002781

Alto	Ancho	Formato
10mm	14mm	CR100m

Material	SIL. 65° ROJO TEJA
----------	--------------------

10000106

Alto	Ancho	Formato
14mm	15mm	CR50m

Material	EPDM 70° NEGRO
----------	----------------

10000762

Alto	Ancho	Formato
10mm	15mm	CR50m

Material	EPDM 70° NEGRO
----------	----------------

10000746

Alto	Ancho	Formato
15mm	15mm	CR50m

Material	EPDM 70° NEGRO
----------	----------------



100H1545

Alto	Ancho	Formato
14mm	16mm	CR25m

Material	EPDM 70° NEGRO
----------	----------------

10000765

Alto	Ancho	Formato
15mm	17mm	CR25m

Material	EPDM 70° NEGRO
----------	----------------

10000764

Alto	Ancho	Formato
10mm	20mm	CR50m

Material	EPDM 70° NEGRO
----------	----------------

10000766

Alto	Ancho	Formato
10mm	20mm	CR50m

Material	EPDM 70° NEGRO
----------	----------------

10000985

Alto	Ancho	Formato
16mm	20mm	R50m

Material	EPDM 70° NEGRO
----------	----------------

10000373

Alto	Ancho	Formato
18mm	20mm	CR25m

Material	EPDM 70° NEGRO
----------	----------------

10001826

Alto	Ancho	Formato
13,5mm	25mm	CR50m

Material	EPDM 70° NEGRO
----------	----------------

10001799

Alto	Ancho	Formato
15mm	25mm	CR50m

Material	EPDM 70° NEGRO
----------	----------------

10000510

Alto	Ancho	Formato
21,5mm	35,5mm	R25m

Material	EPDM 70° NEGRO
----------	----------------

10001145

Alto	Ancho	Formato
24mm	40mm	R20m

Material	EPDM 70° NEGRO
----------	----------------

10004256

Alto	Ancho	Formato
30mm	50mm	R25m

Material	EPDM 70° NEGRO
----------	----------------

10001242

Alto	Ancho	Formato
35mm	50mm	R20m

Material	EPDM 70° NEGRO
----------	----------------

10004210

Alto	Ancho	Formato
35mm	50mm	TIRAS

Material	EPDM 60° NEGRO
----------	----------------

10002771

Alto	Ancho	Formato
22mm	100mm	R10m

Material	EPDM 70° NEGRO
----------	----------------



10003327

Regata	Alto	Formato
0,9mm	8mm	R750m

Material	POLIETILENO 90°
----------	-----------------

10002445

Regata	Alto	Formato
1mm	5,4mm	CR50m

Material	EPDM 70° NEGRO
----------	----------------

10003505

Regata	Alto	Formato
1mm	6mm	CR100m

Material	EPDM 70° NEGRO
----------	----------------

10000922

Regata	Alto	Formato
1mm	8mm	CR100m

Material	SIL. 70° TRANS.
----------	-----------------

10002189

Regata	Alto	Formato
1mm	8mm	CR200m

Material	EPDM 70° NEGRO
----------	----------------

10000229

Regata	Alto	Formato
1mm	8,5mm	CR100m

Material	EPDM 70° NEGRO
----------	----------------

10000966

Regata	Alto	Formato
1mm	9mm	CR100m

Material	SIL. 65° TRANS.
----------	-----------------

10000755

Regata	Alto	Formato
1mm	10mm	CR100m

Material	EPDM 70° NEGRO
----------	----------------

10000756

Regata	Alto	Formato
1mm	12mm	CR100m

Material	EPDM 70° NEGRO
----------	----------------

10001528

Regata	Alto	Formato
1mm	15mm	CR100m

Material	EPDM 70° NEGRO
----------	----------------

10002795

Regata	Alto	Formato
1mm	18,1mm	CR100m

Material	EPDM 70° NEGRO
----------	----------------

10001590

Regata	Alto	Formato
1,25mm	6,5mm	CR200m

Material	EPDM 70° NEGRO
----------	----------------

10003899

Regata	Alto	Formato
1,3mm	11mm	CR200m

Material	EPDM 70° NEGRO
----------	----------------

10001216

Regata	Alto	Formato
1,3mm	16,5mm	CR100m

Material	EPDM 70° NEGRO
----------	----------------

10000155

Regata	Alto	Formato
1,5mm	6mm	CR100m

Material	EPDM 70° NEGRO
----------	----------------

10000248

Regata	Alto	Formato
1,5mm	6mm	CR200m

Material	NBR 70° NEGRO
----------	---------------



10001194

Regata	Alto	Formato
1,5mm	8,5mm	CR200m

Material	EPDM 70° NEGRO
----------	----------------

10000758

Regata	Alto	Formato
1,5mm	9mm	CR100m

Material	EPDM 70° NEGRO
----------	----------------

10004326

Regata	Alto	Formato
1,5mm	9,5mm	CR250m

Material	EPDM IGN 70° NEGRO
----------	--------------------

10003677

Regata	Alto	Formato
1,5mm	10mm	CR200m

Material	EPDM 70° NEGRO
----------	----------------

10001033

Regata	Alto	Formato
1,5mm	11mm	CR100m

Material	EPDM 70° NEGRO
----------	----------------

10000997

Regata	Alto	Formato
1,5mm	11mm	R100m

Material	EPDM 70° NEGRO
----------	----------------

10002042

Regata	Alto	Formato
1,5mm	12mm	CR100m

Material	EPDM 70° NEGRO
----------	----------------

10000487

Regata	Alto	Formato
1,5mm	12,5mm	CR100m

Material	EPDM 70° NEGRO
----------	----------------

10001966

Regata	Alto	Formato
1,5mm	12,5mm	CR100m

Material	EPDM 70° BLANCO
----------	-----------------

1003904

Regata	Alto	Formato
1,5mm	13mm	CR100m

Material	EPDM 70° NEGRO
----------	----------------

10001012

Regata	Alto	Formato
1,5mm	13,5mm	CR100m

Material	SILICONA 65° TRANS.
----------	---------------------

10000139

Regata	Alto	Formato
1,5mm	13,5mm	CR100m

Material	EPDM 70° NEGRO
----------	----------------

10002043

Regata	Alto	Formato
1,5mm	15mm	CR100m

Material	EPDM 70° NEGRO
----------	----------------

1000666

Regata	Alto	Formato
1,5mm	13,5mm	CR100m

Material	SILICONA 65° NEGRA
----------	--------------------

10000810

Regata	Alto	Formato
1,55mm	7mm	CR100m

Material	EPDM 70° NEGRO
----------	----------------

10003900

Regata	Alto	Formato
1,55mm	17,5mm	CR100m

Material	EPDM 70° NEGRO
----------	----------------



10004178

Regata	Alto	Formato
1,6mm	7,5mm	CR250m

Material	SILICONA 30° TRANS.
----------	---------------------

10003207

Regata	Alto	Formato
1,7mm	6mm	CR200m

Material	NEOPRENO 70° NEGRO
----------	--------------------

1000691

Regata	Alto	Formato
2mm	5mm	CR250m

Material	EPDM 70° NEGRO
----------	----------------

10002836

Regata	Alto	Formato
2mm	6mm	CR250m

Material	EPDM 70° NEGRO
----------	----------------

10001951

Regata	Alto	Formato
2mm	7,5mm	CR100m

Material	EPDM 70° NEGRO
----------	----------------

10001200

Regata	Alto	Formato
2mm	8mm	CR100m

Material	EPDM 70° NEGRO
----------	----------------

10003593

Regata	Alto	Formato
2mm	8mm	CR200m

Material	EPDM IGN 70° NEGRO
----------	--------------------

10001745

Regata	Alto	Formato
2mm	9mm	CR100m

Material	EPDM 70° NEGRO
----------	----------------

10003090

Regata	Alto	Formato
2mm	9mm	TIRAS

Material	EPDM 70° NEGRO
----------	----------------

10003800

Regata	Alto	Formato
2mm	9mm	CR200m

Material	EPDM 70° NEGRO
----------	----------------

10000988

Regata	Alto	Formato
2mm	10mm	R100m

Material	EPDM 70° NEGRO
----------	----------------

10003903

Regata	Alto	Formato
2mm	11mm	CR200m

Material	EPDM 70° NEGRO
----------	----------------

10002888

Regata	Alto	Formato
2mm	12mm	CR100m

Material	EPDM IGN 70° NEGRO
----------	--------------------

10000759

Regata	Alto	Formato
2mm	12mm	CR100m

Material	EPDM 70° NEGRO
----------	----------------

10000760

Regata	Alto	Formato
2mm	12mm	CR50m

Material	EPDM 70° NEGRO
----------	----------------

10000925

Regata	Alto	Formato
2mm	12mm	CR100m

Material	EPDM 70° NEGRO
----------	----------------



10001007

Regata	Alto	Formato
2mm	12mm	R100m

Material	EPDM 70° NEGRO
----------	----------------

10001497

Regata	Alto	Formato
2mm	12mm	CR100m

Material	EPDM 70° NEGRO
----------	----------------

10000417

Regata	Alto	Formato
2mm	12,7mm	CR100m

Material	EPDM 70° NEGRO
----------	----------------

10000613

Regata	Alto	Formato
2mm	14mm	CR100m

Material	EPDM 70° NEGRO
----------	----------------

10001089

Regata	Alto	Formato
2mm	15mm	R100m

Material	EPDM 70° NEGRO
----------	----------------

10000924

Regata	Alto	Formato
2mm	15mm	CR100m

Material	EPDM 70° NEGRO
----------	----------------

10003765

Regata	Alto	Formato
2mm	16,2mm	CR100m

Material	EPDM 70° NEGRO
----------	----------------

10000269

Regata	Alto	Formato
2mm	16,2mm	CR100m

Material	EPDM 70° BLANCO
----------	-----------------

10001141

Regata	Alto	Formato
2mm	17,2mm	CR100m

Material	EPDM 70° NEGRO
----------	----------------

10000075

Regata	Alto	Formato
2,4mm	12mm	CR100m

Material	SILICONA 65° TRANS.
----------	---------------------

10001677

Regata	Alto	Formato
2,5mm	8mm	CR100m

Material	NBR 70° NEGRO
----------	---------------

10002941

Regata	Alto	Formato
2,5mm	8,5mm	CR100m

Material	EPDM 70° NEGRO
----------	----------------

10001262

Regata	Alto	Formato
2,5mm	10mm	CR100m

Material	EPDM 70° NEGRO
----------	----------------

10001026

Regata	Alto	Formato
2,5mm	10,9mm	CR100m

Material	EPDM 70° NEGRO
----------	----------------

10001027

Regata	Alto	Formato
2,5mm	13mm	CR100m

Material	EPDM 70° NEGRO
----------	----------------

10000616

Regata	Alto	Formato
2,5mm	16mm	CR100m

Material	EPDM 70° NEGRO
----------	----------------



10002102

Regata	Alto	Formato
2,6mm	19,9mm	CR120m

Material	EPDM 70° NEGRO
----------	----------------

10002334

Regata	Alto	Formato
2,8mm	14mm	CR100m

Material	EPDM 70° NEGRO
----------	----------------

10004191

Regata	Alto	Formato
2,8mm	15mm	CR100m

Material	SILICONA TRANS 50°
----------	--------------------

10003243

Regata	Alto	Formato
3mm	5mm	CR200m

Material	EPDM 70° NEGRO
----------	----------------

10004298

Regata	Alto	Formato
3mm	8mm	CR250m

Material	EPDM IGN 70° NEGRO
----------	--------------------

10000917

Regata	Alto	Formato
3mm	9mm	R500m

Material	EPDM 70° NEGRO
----------	----------------

10004213

Regata	Alto	Formato
3mm	9mm	CR100m

Material	EPDM 70° NEGRO
----------	----------------

10000846

Regata	Alto	Formato
3mm	9,2mm	CR50m

Material	EPDM 70° NEGRO
----------	----------------

10001110

Regata	Alto	Formato
3mm	10mm	CR100m

Material	EPDM 70° NEGRO
----------	----------------

10004284

Regata	Alto	Formato
3mm	10,4mm	CR100m

Material	EPDM IGN 70° NEGRO
----------	--------------------

10002643

Regata	Alto	Formato
3mm	12mm	CR100m

Material	EPDM 70° NEGRO
----------	----------------

10003163

Regata	Alto	Formato
3mm	13,5mm	CR100m

Material	EPDM 70° NEGRO
----------	----------------

10003904

Regata	Alto	Formato
3mm	13mm	CR100m

Material	EPDM 70° NEGRO
----------	----------------

10000538

Regata	Alto	Formato
3mm	15mm	CR100m

Material	EPDM 70° NEGRO
----------	----------------

10000617

Regata	Alto	Formato
3mm	16mm	CR50m

Material	EPDM 70° NEGRO
----------	----------------

10004286

Regata	Alto	Formato
3mm	18mm	CR75m

Material	EPDM IGN 70° NEGRO
----------	--------------------



10002716

Regata	Alto	Formato
3mm	20mm	CR25m

Material	EPDM 70° NEGRO
----------	----------------

10001519

Regata	Alto	Formato
3mm	20mm	CR50m

Material	EPDM 70° NEGRO
----------	----------------

10001964

Regata	Alto	Formato
3mm	20mm	CR25m

Material	EPDM 70° GRIS
----------	---------------

10003423

Regata	Alto	Formato
3mm	24,5mm	CR50m

Material	EPDM 70° NEGRO
----------	----------------

10001125

Regata	Alto	Formato
3mm	25mm	R25m

Material	EPDM 70° NEGRO
----------	----------------

10003972

Regata	Alto	Formato
3mm	25mm	CR50m

Material	EPDM 70° NEGRO
----------	----------------

10003033

Regata	Alto	Formato
3mm	32mm	CR50m

Material	EPDM 70° NEGRO
----------	----------------

10001644

Regata	Alto	Formato
3,5mm	19mm	R25m

Material	EPDM 70° NEGRO
----------	----------------

10000856

Regata	Alto	Formato
3,7mm	13,5mm	CR100m

Material	EPDM 70° NEGRO
----------	----------------

10003831

Regata	Alto	Formato
4mm	9mm	R90m

Material	EPDM 70° NEGRO
----------	----------------

10003517

Regata	Alto	Formato
4mm	10mm	CR200m

Material	EPDM 70° NEGRO
----------	----------------

10002756

Regata	Alto	Formato
4mm	11mm	CR100m

Material	EPDM 70° NEGRO
----------	----------------

10000079

Regata	Alto	Formato
4mm	12mm	CR100m

Material	EPDM 70° NEGRO
----------	----------------

10000748

Regata	Alto	Formato
4mm	12mm	CR100m

Material	EPDM 70° NEGRO
----------	----------------

10000889

Regata	Alto	Formato
4mm	12mm	CR100m

Material	EPDM 70° NEGRO
----------	----------------

10001233

Regata	Alto	Formato
4mm	12mm	CR50m

Material	EPDM 70° NEGRO
----------	----------------



10002320

Regata	Alto	Formato
4mm	12mm	CR100m

Material	EPDM 70° NEGRO
----------	----------------

10004700

Regata	Alto	Formato
3.5mm	34mm	CR25m

Material	SILICONA TRANS.
----------	-----------------

10001524

Regata	Alto	Formato
4mm	15mm	CR100m

Material	EPDM 70° NEGRO
----------	----------------

10001517

Regata	Alto	Formato
4mm	15mm	CR100m

Material	EPDM 70° NEGRO
----------	----------------

10003901

Regata	Alto	Formato
4mm	15mm	CR100m

Material	EPDM 70° NEGRO
----------	----------------

10003314

Regata	Alto	Formato
4mm	20mm	CR50m

Material	EPDM 70° NEGRO
----------	----------------

10002534

Regata	Alto	Formato
4mm	26mm	R25m

Material	EPDM 70° NEGRO
----------	----------------

10002575

Regata	Alto	Formato
4mm	30mm	CR25m

Material	EPDM 70° NEGRO
----------	----------------

10002864

Regata	Alto	Formato
4mm	38mm	CR50m

Material	EPDM IGN 70° NEGRO
----------	--------------------

10000945

Regata	Alto	Formato
4,5mm	8mm	CR100m

Material	EPDM 70° NEGRO
----------	----------------

10000961

Regata	Alto	Formato
4,5mm	17,5mm	CR50m

Material	NBR 70° NEGRO
----------	---------------

10002502

Regata	Alto	Formato
4,8mm	19,7mm	CR50m

Material	EPDM 70° NEGRO
----------	----------------

10003460

Regata	Alto	Formato
5mm	6,1mm	CR200m

Material	EPDM 70° NEGRO
----------	----------------

10004069

Regata	Alto	Formato
5mm	11mm	CR100m

Material	EPDM 70° NEGRO
----------	----------------

10003192

Regata	Alto	Formato
5mm	12,4mm	CR100m

Material	EPDM 70° NEGRO
----------	----------------

10000614

Regata	Alto	Formato
5mm	13mm	CR100m

Material	EPDM 70° NEGRO
----------	----------------



10003126

Regata	Alto	Formato
5mm	14,5mm	CR100m

Material	EPDM 70° NEGRO
----------	----------------

10004287

Regata	Alto	Formato
5mm	16mm	CR75m

Material	EPDM IGN 70° NEGRO
----------	--------------------

10002014

Regata	Alto	Formato
5mm	18mm	CR50m

Material	EPDM 70° NEGRO
----------	----------------

10004176

Regata	Alto	Formato
5mm	18mm	CR50m

Material	EPDM 70° NEGRO
----------	----------------

10001500

Regata	Alto	Formato
5mm	19mm	CR50m

Material	EPDM 70° NEGRO
----------	----------------

10001518

Regata	Alto	Formato
5mm	20mm	CR50m

Material	EPDM 70° NEGRO
----------	----------------

10000615

Regata	Alto	Formato
5mm	22mm	CR100m

Material	EPDM 70° NEGRO
----------	----------------

10004308

Regata	Alto	Formato
5mm	23mm	CR30m

Material	EPDM 70° NEGRO
----------	----------------

10001086

Regata	Alto	Formato
5mm	25mm	CR25m

Material	EPDM 50° NEGRO
----------	----------------

10001106

Regata	Alto	Formato
5mm	25mm	CR25m

Material	EPDM 70° NEGRO
----------	----------------

10003529

Regata	Alto	Formato
5mm	43mm	CR100m

Material	EPDM 70° NEGRO
----------	----------------

10003529

Regata	Alto	Formato
5,1mm	30mm	R50m

Material	EPDM 70° NEGRO
----------	----------------

10001751

Regata	Alto	Formato
6mm	11mm	CR100m

Material	EPDM 70° NEGRO
----------	----------------

10002750

Regata	Alto	Formato
6mm	13mm	CR100m

Material	EPDM 70° NEGRO
----------	----------------

10000785

Regata	Alto	Formato
6mm	15mm	CR50m

Material	EPDM 70° NEGRO
----------	----------------

10000140

Regata	Alto	Formato
6mm	15mm	CR50m

Material	EPDM 70° NEGRO
----------	----------------



10003050

Regata	Alto	Formato
6mm	15mm	CR50m

Material	SILICONA 70° TRANS.
----------	---------------------

10000749

Regata	Alto	Formato
6mm	18mm	CR50m

Material	EPDM 70° NEGRO
----------	----------------

10000875

Regata	Alto	Formato
6mm	20,5mm	CR100m

Material	EPDM 70° NEGRO
----------	----------------

10003315

Regata	Ancho	Formato
6mm	25mm	CR100m

Material	SILICONA 70° TRANS.
----------	---------------------

10001085

Regata	Alto	Formato
6mm	33,5mm	CR25m

Material	EPDM 70° NEGRO
----------	----------------

10003304

Regata	Alto	Formato
6mm	38mm	R25m

Material	EPDM 70° NEGRO
----------	----------------

100H1498

Regata	Alto	Formato
6mm	46mm	CR100m

Material	SIL. HT 70° NEGRO
----------	-------------------

10000418

Regata	Alto	Formato
7mm	15mm	CR50m

Material	EPDM 70° NEGRO
----------	----------------

10000750

Regata	Ancho	Formato
7mm	15mm	CR50m

Material	EPDM 70° NEGRO
----------	----------------

10003902

Regata	Alto	Formato
7mm	15,5mm	CR100m

Material	EPDM 70° NEGRO
----------	----------------

10003830

Regata	Alto	Formato
7mm	16,5mm	R90m

Material	EPDM 70° NEGRO
----------	----------------

10002714

Regata	Alto	Formato
7mm	20mm	R50m

Material	EPDM 70° NEGRO
----------	----------------

10001249

Regata	Alto	Formato
7mm	30mm	CR25m

Material	EPDM 70° NEGRO
----------	----------------

10002413

Regata	Ancho	Formato
7,5mm	9,7mm	CR250m

Material	EPDM 70° NEGRO
----------	----------------

10000619

Regata	Alto	Formato
7,8mm	17mm	CR100m

Material	EPDM 70° NEGRO
----------	----------------

10003255

Regata	Alto	Formato
8mm	12mm	CR100m

Material	EPDM 70° NEGRO
----------	----------------



10002106

Regata	Alto	Formato
8mm	13,5mm	CR100m

Material EPDM 70° NEGRO

10000689

Regata	Ancho	Formato
8mm	13mm	CR100m

Material EPDM 70° NEGRO

10002657

Regata	Alto	Formato
8mm	14mm	CR100m

Material EPDM 70° NEGRO

10003324

Regata	Alto	Formato
8mm	14,5mm	CR100m

Material EPDM 70° NEGRO

10003584

Regata	Alto	Formato
8mm	15mm	CR100m

Material EPDM 70° NEGRO

10000753

Regata	Alto	Formato
8mm	16mm	CR50m

Material EPDM 70° NEGRO

10002999

Regata	Alto	Formato
8mm	16mm	CR50m

Material SILICONA 70° GRIS

10002337

Regata	Alto	Formato
8mm	18mm	CR50m

Material EPDM 70° NEGRO

10000751

Regata	Alto	Formato
8mm	21mm	CR50m

Material EPDM 70° NEGRO

10004214

Regata	Alto	Formato
8mm	22mm	R50m

Material EPDM 70° NEGRO

10001659

Regata	Alto	Formato
8mm	25mm	CR25m

Material EPDM 70° NEGRO

100H1495

Regata	Alto	Formato
9mm	13mm	CR50m

Material EPDM 70° NEGRO

10000752

Regata	Alto	Formato
9mm	15mm	CR50m

Material EPDM 70° NEGRO

10001665

Regata	Alto	Formato
9mm	25mm	CR25m

Material EPDM 70° NEGRO

10003762

Regata	Alto	Formato
9mm	28mm	CR50m

Material NEOPRENO 70° NEGRO

10003971

Regata	Alto	Formato
9mm	28mm	R25m

Material EPDM 70° NEGRO



10004036

Regata	Alto	Formato
9,5mm	46mm	R25m

Material	EPDM 70° NEGRO
----------	----------------

10003360

Regata	Alto	Formato
10mm	35mm	TIRAS

Material	EPDM 70° NEGRO
----------	----------------

10003414

Regata	Alto	Formato
10mm	12mm	CR100m

Material	EPDM 70° NEGRO
----------	----------------

10000200

Regata	Alto	Formato
10mm	15mm	CR100m

Material	EPDM 70° NEGRO
----------	----------------

10003298

Regata	Alto	Formato
10mm	15mm	CR100m

Material	EPDM 70° NEGRO
----------	----------------

10001664

Regata	Alto	Formato
10mm	25mm	CR25m

Material	EPDM 70° NEGRO
----------	----------------

10003131

Regata	Alto	Formato
10mm	25,8mm	CR50m

Material	EPDM 70° NEGRO
----------	----------------

10002693

Regata	Alto	Formato
10mm	27mm	R25m

Material	EPDM 70° NEGRO
----------	----------------

10004056

Regata	Alto	Formato
10mm	31mm	R25m

Material	EPDM 70° NEGRO
----------	----------------

10001788

Regata	Alto	Formato
10mm	49mm	CR100m

Material	EPDM 70° NEGRO
----------	----------------

10001248

Regata	Alto	Formato
10,5mm	50mm	R25m

Material	EPDM 70° NEGRO
----------	----------------

10002576

Regata	Alto	Formato
11mm	55mm	R25m

Material	EPDM 70° NEGRO
----------	----------------

10001501

Regata	Alto	Formato
12mm	17mm	CR50m

Material	EPDM 70° NEGRO
----------	----------------

10002494

Regata	Alto	Formato
12mm	18mm	CR50m

Material	EPDM 70° NEGRO
----------	----------------

10000754

Regata	Alto	Formato
12mm	20mm	CR50m

Material	EPDM 70° NEGRO
----------	----------------

10003225

Regata	Alto	Formato
12mm	29mm	CR50m

Material	EPDM 70° NEGRO
----------	----------------



10002841

Regata	Alto	Formato
12mm	35mm	R25m

Material	EPDM 70° NEGRO
----------	----------------

10002757

Regata	Alto	Formato
12mm	35mm	R50m

Material	EPDM 70° NEGRO
----------	----------------

10000442

Regata	Alto	Formato
12mm	35,5mm	CR25m

Material	EPDM 70° NEGRO
----------	----------------

10003540

Regata	Alto	Formato
12,2mm	43,3mm	CR100m

Material	EPDM 70° NEGRO
----------	----------------

10003387

Regata	Alto	Formato
12,5mm	50mm	R25m

Material	EPDM 70° NEGRO
----------	----------------

10003710

Regata	Alto	Formato
13mm	26mm	R25m

Material	EPDM 70° NEGRO
----------	----------------

10001672

Regata	Ancho	Formato
13,5mm	29,5mm	R25m

Material	EPDM 70° NEGRO
----------	----------------

100H1313

Regata	Ancho	Formato
14mm	27mm	R25m

Material	EPDM 60° NEGRO
----------	----------------

10002332

Regata	Alto	Formato
14,5mm	36,8mm	R25m

Material	EPDM 70° NEGRO
----------	----------------

10003875

Regata	Alto	Formato
15mm	18mm	R25

Material	NBR 70° NEGRO
----------	---------------

10003565

Regata	Alto	Formato
15mm	32mm	R25m

Material	EPDM 70° NEGRO
----------	----------------

10002721

Regata	Ancho	Formato
15mm	46mm	R25

Material	EPDM 70° NEGRO
----------	----------------

10002432

Regata	Alto	Formato
15,8mm	37mm	R30m

Material	EPDM 70° NEGRO
----------	----------------

10002626

Regata	Alto	Formato
16mm	38mm	R50m

Material	EPDM 70° NEGRO
----------	----------------

10003531

Regata	Ancho	Formato
16,9mm	23,1mm	R50m

Material	NEOPRENO 70° NEGRO
----------	--------------------

10001666

Regata	Alto	Formato
18mm	7mm	CR100m

Material	EPDM 70° NEGRO
----------	----------------



10001250

Regata	Alto	Formato
18mm	20,4mm	R25m

Material	EPDM 70° NEGRO
----------	----------------

100H1496

Regata	Alto	Formato
18mm	20,7mm	R25m

Material	NBR 70° NEGRO
----------	---------------

10002722

Regata	Alto	Formato
18mm	44mm	R25m

Material	EPDM 70° NEGRO
----------	----------------

10000935

Regata	Ancho	Formato
18,4mm	24mm	CR25m

Material	EPDM 70° NEGRO
----------	----------------

10001509

Regata	Alto	Formato
18,5mm	17mm	CR50m

Material	EPDM 70° NEGRO
----------	----------------

10002561

Regata	Alto	Formato
19mm	35mm	R25m

Material	EPDM 70° NEGRO
----------	----------------

10001952

Regata	Alto	Formato
19mm	35mm	CR25m

Material	EPDM 70° NEGRO
----------	----------------

10003348

Regata	Ancho	Formato
20mm	12mm	CR50m

Material	EPDM 70° NEGRO
----------	----------------

10003436

Regata	Alto	Formato
20mm	12mm	CR100m

Material	EPDM 70° NEGRO
----------	----------------

10001944

Regata	Alto	Formato
20mm	22mm	R50m

Material	EPDM 70° NEGRO
----------	----------------

10001902

Regata	Alto	Formato
20mm	35mm	R25m

Material	EPDM 70° NEGRO
----------	----------------

10000996

Regata	Alto	Formato
24mm	23mm	R50m

Material	EPDM 70° NEGRO
----------	----------------

10004215

Regata	Alto	Formato
20mm	25mm	CR50m

Material	EPDM 70° NEGRO
----------	----------------

10002827

Regata	Alto	Formato
25mm	35mm	R50m

Material	EPDM 70° NEGRO
----------	----------------

10004145

Regata	Alto	Formato
26mm	20mm	R50m

Material	EPDM 70° NEGRO
----------	----------------

10002390

Regata	Alto	Formato
30mm	23mm	R50m

Material	EPDM 70° NEGRO
----------	----------------



EPDM / CEDULAR PERFILES FORMA U

10002500

Regata	Alto	Formato
30mm	55mm	R25m

Material	EPDM 70° NEGRO
----------	----------------

10002506

Regata	Alto	Formato
30mm	36mm	R25m

Material	EPDM 70° NEGRO
----------	----------------

10003413

Regata	Alto	Formato
35mm	20,50mm	CR25m

Material	EPDM 70° NEGRO
----------	----------------

10002365

Regata	Ancho	Formato
38mm	50mm	TIRAS

Material	EPDM 70° NEGRO
----------	----------------

10002397

Regata	Alto	Formato
40mm	24mm	R29m

Material	EPDM 70° NEGRO
----------	----------------

10002481

Regata	Alto	Formato
40mm	48mm	R25m

Material	EPDM 70° NEGRO
----------	----------------

10001499

Regata	Alto	Formato
41mm	45mm	TIRAS

Material	EPDM 70° NEGRO
----------	----------------

10003750

Regata	Ancho	Formato
50mm	6mm	R25m

Material	EPDM 70° NEGRO
----------	----------------

10004158

Regata	Alto	Formato
61mm	8mm	R25m

Material	EPDM 70° NEGRO
----------	----------------

10003713

Regata	Alto	Formato
70mm	80mm	TIRAS

Material	EPDM 70° NEGRO
----------	----------------

10000827

Regata	Alto	Formato
91mm	11mm	R25m

Material	EPDM 70° NEGRO
----------	----------------

10000318

Regata	Alto	Formato
91mm	11mm	R25

Material	EPDM 70° BLANCO
----------	-----------------

10002220

Regata	Alto	Formato
101mm	11,5mm	R25m

Material	EPDM 70° NEGRO
----------	----------------



10000718

Regata	Alto	Formato
2mm	11mm	CR100m

Material	EPDM CED. 0,65°
----------	-----------------

10004026

Regata	Alto	Formato
2mm	13mm	CR100m

Material	EPDM CED. 0,65°
----------	-----------------

10000721

Regata	Alto	Formato
3mm	12mm	CR50m

Material	EPDM CED. 0,60°
----------	-----------------

10000719

Regata	Alto	Formato
3mm	15mm	CR50m

Material	EPDM CED. 0,75°
----------	-----------------

10003506

Regata	Alto	Formato
3mm	15mm	CR100m

Material	EPDM CED. 0,65°
----------	-----------------

10003931

Regata	Alto	Formato
3mm	20mm	CR200m

Material	EPDM CED. 0,60°
----------	-----------------

10000717

Regata	Alto	Formato
4mm	10mm	CR100m

Material	EPDM CED. 0,60°
----------	-----------------

10000720

Regata	Alto	Formato
6mm	12mm	CR50m

Material	EPDM CED. 0,60°
----------	-----------------

10004602 *

Regata	Alto	Formato
6mm	12mm	CR100

Material	EPDM CED. 0,60°
----------	-----------------



10000722

Alto	Ancho	Formato
6mm	15mm	CR100m

Material	EPDM 70° NEGRO
----------	----------------

10000723

Alto	Ancho	Formato
7mm	15mm	CR100m

Material	EPDM 70° NEGRO
----------	----------------

10002540

Alto	Ancho	Formato
10mm	16mm	CR50m

Material	EPDM 70° NEGRO
----------	----------------

10002541 ADH

Alto	Ancho	Formato
10mm	16mm	CR50m

Material	EPDM 70° NEGRO
----------	----------------

10002768 ADH

Alto	Ancho	Formato
10mm	16mm	CR50m

Material	EPDM 70° NEGRO
----------	----------------

10002769

Alto	Ancho	Formato
10mm	16mm	CR50m

Material	EPDM 70° NEGRO
----------	----------------

10000114

Alto	Ancho	Formato
5mm	18mm	CR100m

Material	EPDM 70° NEGRO
----------	----------------

10000690

Alto	Ancho	Formato
4mm	19mm	CR100m

Material	EPDM 70° NEGRO
----------	----------------

10000724

Alto	Ancho	Formato
8mm	20mm	CR50m

Material	EPDM 70° NEGRO
----------	----------------

10002578

Alto	Ancho	Formato
8mm	20mm	CR50m

Material	SILICONA 65° AZUL
----------	-------------------

10000727

Alto	Ancho	Formato
10mm	25mm	CR50m

Material	EPDM 70° NEGRO
----------	----------------

10000731

Alto	Ancho	Formato
6mm	26mm	CR100m

Material	EPDM 70° NEGRO
----------	----------------

10000725

Alto	Ancho	Formato
8mm	26mm	CR50m

Material	EPDM 70° NEGRO
----------	----------------

10000732

Alto	Ancho	Formato
6mm	29mm	CR100m

Material	EPDM 70° NEGRO
----------	----------------

10000726

Alto	Ancho	Formato
9mm	29mm	CR50m

Material	EPDM 70° NEGRO
----------	----------------

10001035

Alto	Ancho	Formato
9,6mm	29mm	CR50m

Material	EPDM 70° NEGRO
----------	----------------



10000728		
Alto	Ancho	Formato
10mm	30mm	CR50m
Material	EPDM 70° NEGRO	

10000729		
Alto	Ancho	Formato
12mm	30mm	CR50m
Material	EPDM 70° NEGRO	

10000730		
Alto	Ancho	Formato
13mm	30mm	CR100m
Material	EPDM 70° NEGRO	

1003289		
Alto	Ancho	Formato
25mm	35mm	R25m
Material	EPDM 70° NEGRO	

10002998		
Alto	Ancho	Formato
10mm	36mm	CR100m
Material	EPDM 70° NEGRO	

10000222		
Alto	Ancho	Formato
17mm	40mm	CR25m
Material	EPDM 70° NEGRO	

10001617		
Alto	Ancho	Formato
10mm	43mm	CR50m
Material	SIL. 60° ROJO VIVO	

10003292		
Alto	Ancho	Formato
15mm	45mm	CR50m
Material	EPDM 70° NEGRO	

10004238		
Alto	Ancho	Formato
30mm	50mm	R25m
Material	EPDM 70° NEGRO	

10003147		
Alto	Ancho	Formato
22mm	54mm	R25m
Material	EPDM 70° NEGRO	

10003322		
Alto	Ancho	Formato
30mm	60mm	CR25m
Material	EPDM 70° NEGRO	

10003096		
Alto	Ancho	Formato
25mm	60mm	R25m
Material	EPDM 70° NEGRO	

10002491		
Alto	Ancho	Formato
30mm	65mm	R25m
Material	EPDM 70° NEGRO	

1001674		
Alto	Ancho	Formato
20mm	70mm	R25m
Material	EPDM 70° NEGRO	

10001731		
Alto	Ancho	Formato
35mm	70mm	R25m
Material	EPDM 70° NEGRO	

10002062		
Alto	Ancho	Formato
21,5mm	73,5mm	R25m
Material	EPDM 70° NEGRO	



10001675		
Alto	Ancho	Formato
17,5mm	74mm	CR25m
Material	EPDM 70° NEGRO	

10001787		
Alto	Ancho	Formato
35mm	75mm	CR25m
Material	EPDM 70° NEGRO	

10001585		
Alto	Ancho	Formato
32mm	76mm	R25m
Material	EPDM 70° NEGRO	

10002987		
Alto	Ancho	Formato
25mm	80mm	R12m
Material	EPDM 70° NEGRO	

10002351		
Alto	Ancho	Formato
10mm	90mm	R50m
Material	EPDM 70° NEGRO	

10003503		
Alto	Ancho	Formato
29mm	90mm	R25m
Material	EPDM 70° NEGRO	

10002723		
Alto	Ancho	Formato
40mm	95mm	R10m
Material	EPDM 70° NEGRO	

10003548		
Alto	Ancho	Formato
11mm	100mm	R50m
Material	EPDM 70° NEGRO	

10000225		
Alto	Ancho	Formato
32mm	110mm	CR25m
Material	EPDM 70° NEGRO	

10004622 *		
Regata	Ancho	Formato
4mm	30mm	CR100
Material	EPDM IGN NEGRO	

10004602 *		
Regata	Alto	Formato
16mm	12mm	CR100
Material	EPDM 70° NEGRO	

10002429

Alto	Ancho	Formato
21mm	44mm	R10m

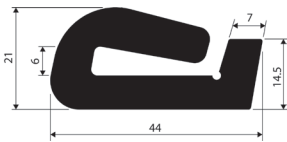

Material	EPDM 50° NEGRO
----------	----------------

10003433

Alto	Ancho	Formato
6,7mm	12mm	CR100m

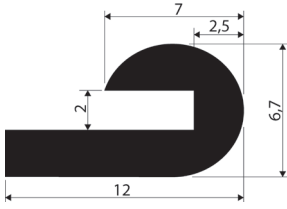

Material	EPDM 70° NEGRO
----------	----------------

10004302

Alto	Ancho	Formato
19,5mm	26,3mm	CR50m

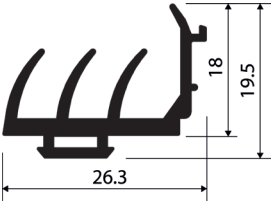

Material	EPDM 70° NEGRO
----------	----------------

10004290

Alto	Ancho	Formato
4mm	9,5mm	CR250m

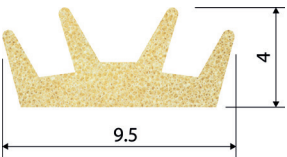

Material	ESP-EPDM 0.65°
----------	----------------

10001752

Alto	Ancho	Formato
20mm	25mm	R50m

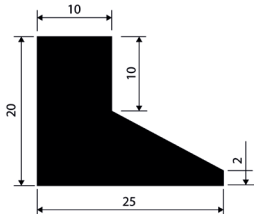

Material	EPDM 70° NEGRO
----------	----------------

10001770

Alto	Ancho	Formato
12,75mm	29,8mm	CR50m

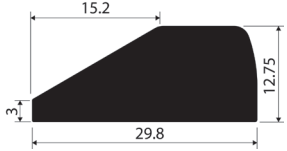

Material	EPDM 70° NEGRO
----------	----------------

10001516

Alto	Ancho	Formato
12mm	28mm	CR50m

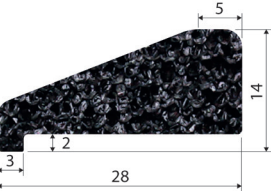

Material	EPDM CED. 0,80°
----------	-----------------

10001638

Alto	Ancho	Formato
20mm	30,32mm	CR50m

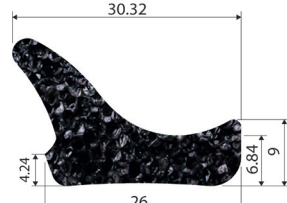

Material	EPDM CED. 0,60°
----------	-----------------

10002761

Alto	Ancho	Formato
6,9mm	18mm	CR100m

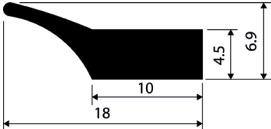

Material	EPDM 70° NEGRO
----------	----------------

10002751

Alto	Ancho	Formato
7,6mm	25,5mm	R36m



Material	EPDM 70° NEGRO
----------	----------------

10001171

Alto	Ancho	Formato
10mm	35mm	CR50m

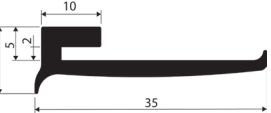

Material	EPDM IGN 70° NEGRO
----------	--------------------

10002555

Alto	Ancho	Formato
13mm	52,3mm	R100m

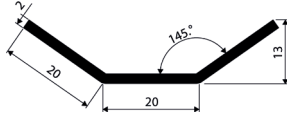

Material	EPDM 70° NEGRO
----------	----------------

10003276

Alto	Ancho	Formato
7mm	26,8mm	R25m

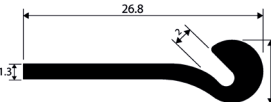

Material	EPDM 70° NEGRO
----------	----------------

10003260

Alto	Ancho	Formato
8,86mm	45,3mm	R50m



Material	EPDM IGN 70° NEGRO
----------	--------------------

10002727

Alto	Ancho	Formato
15mm	21mm	R50m

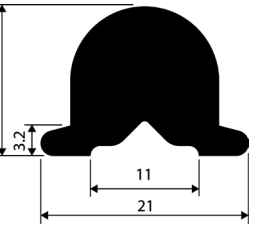

Material	EPDM 70° NEGRO
----------	----------------

10003265

Alto	Ancho	Formato
9,5mm	12,5mm	CR100m



Material	EPDM CED. 0,65°
----------	-----------------

10000998

Alto	Ancho	Formato
23mm	30mm	R100m

Material	EPDM 50° NEGRO
----------	----------------

10000923

Alto	Ancho	Formato
38,25mm	135,27mm	R25m

Material	EPDM 70° NEGRO
----------	----------------

10003093

Alto	Ancho	Formato
36mm	34mm	R25m

Material	EPDM 70° NEGRO
----------	----------------

10001158

Alto	Ancho	Formato
12,5mm	58mm	R50m

Material	NBR 70° NEGRO
----------	---------------

10002523

Alto	Ancho	Formato
5mm	60mm	CR25m

Material	EPDM 80° NEGRO
----------	----------------

10001589

Alto	Ancho	Formato
8,5mm	79mm	R50m

Material	EPDM 70° NEGRO
----------	----------------

10003210

Alto	Ancho	Formato
7,5mm	59,5mm	CR50m

Material	EPDM 70° NEGRO
----------	----------------

10003287

Alto	Ancho	Formato
10mm	120mm	R25m

Material	EPDM 70° NEGRO
----------	----------------

10003773

Alto	Ancho	Formato
4,5mm	28mm	

Material	EPDM 80° NEGRO
----------	----------------

10000705

Alto	Ancho	Formato
6mm	19mm	CR100m

Material	EPDM 70° NEGRO
----------	----------------

10003143

Alto	Ancho	Formato
2,7mm	6,5mm	CR150m

Material	EPDM CED. 0,65°
----------	-----------------

10003211

Alto	Ancho	Formato
5,5mm	25,5mm	CR100m

Material	EPDM 70° NEGRO
----------	----------------

10003146

Alto	Ancho	Formato
29mm	17,5mm	TIRAS

Material	EPDM IGN 70° NEGRO
----------	--------------------

10001061

Alto	Ancho	Formato
14,5mm	10,9mm	CR200m

Material	EPDM 70° BLANCO
----------	-----------------

10003973

Alto	Ancho	Formato
12mm	15mm	TIRAS

Material	EPDM 70° NEGRO
----------	----------------

10002389

Alto	Ancho	Formato
6,8mm	13,5mm	CR200m

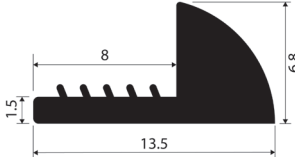

Material	EPDM ING 70° NEGRO
----------	--------------------

10002165

Alto	Ancho	Formato
21mm	24mm	R25m

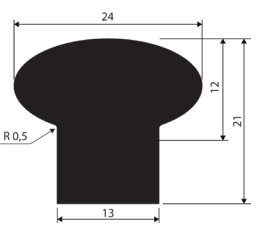

Material	EPDM 70° NEGRO
----------	----------------

10004205

Alto	Ancho	Formato
39,4mm	18mm	CR50m

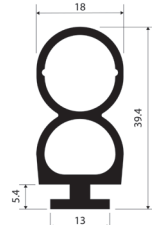

Material	EPDM 70° NEGRO
----------	----------------

10003862

Alto	Ancho	Formato
4mm	9,5mm	CR50m



Material	EPDM 70° NEGRO
----------	----------------

100H1578

Alto	Ancho	Formato
20mm	12mm	CR50m

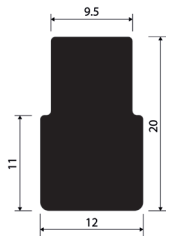

Material	EPDM IGN 70° NEGRO
----------	--------------------

10004291

Alto	Ancho	Formato
31mm	20mm	CR100m

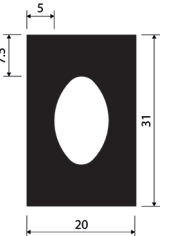

Material	EPDM 70° NEGRO
----------	----------------

10001753

Alto	Ancho	Formato
4,6mm	25mm	CR100m

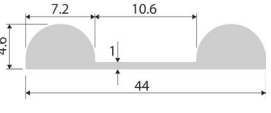

Material	SILICONA 65° TRANS.
----------	---------------------

10001989

Alto	Ancho	Formato
8mm	8mm	CR100m

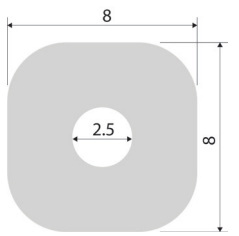

Material	EPDM 70° BLANCO
----------	-----------------

10001990

Alto	Ancho	Formato
9mm	9mm	CR100m

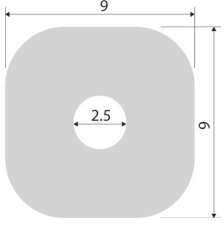

Material	EPDM 70° BLANCO
----------	-----------------

10001991

Alto	Ancho	Formato
10,5mm	10,5mm	CR100m

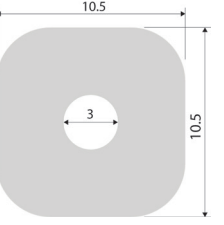

Material	EPDM 70° BLANCO
----------	-----------------

10001992

Alto	Ancho	Formato
11mm	11mm	CR100m

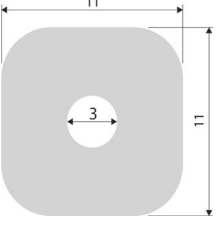

Material	EPDM 70° BLANCO
----------	-----------------

10001993

Alto	Ancho	Formato
12,5mm	12,5mm	CR100m

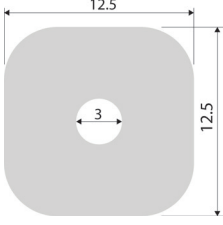

Material	EPDM 70° BLANCO
----------	-----------------

Comprometidos con la calidad

ISO 9001 | ISO 14001 <<

EN 45545 | FDA 177.2600 | DVG WW270 | EN 681-1 | ACS | VW281 | UNE <<

Atención personalizada | Calidad | Tecnología | Piezas a medida <<



Comprometidos con el cliente

- >> Atención personalizada | Calidad | Tecnología
- >> Monitorización del proceso | Piezas a medida